

# CRITICAL CARE TRANSFER STACK INSTRUCTIONS FOR USE

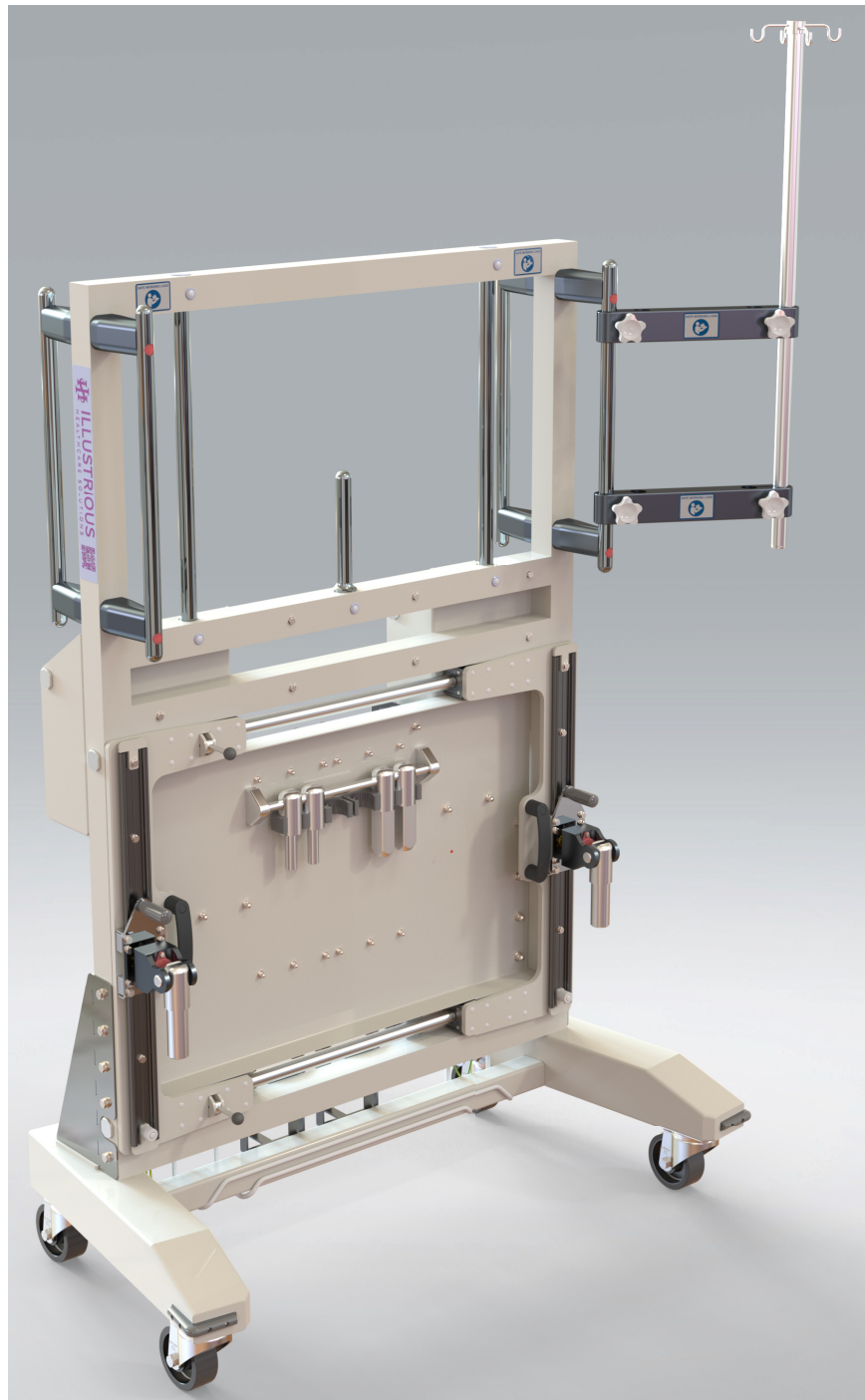





# LIST OF CONTENTS

## LIST OF CONTENTS

	PAGE
<b>LIST OF FIGURES AND TABLES</b>	
INTRODUCTION .....	1
SUMMARY STATEMENT .....	1
DISCLAIMER .....	1
WARRANTY .....	1
DOCUMENT NAVIGATION .....	1
<b>PART 1 GENERAL INFORMATION</b>	
GENERAL SAFETY .....	2
SYMBOLOLOGY .....	3
CCTS IDENTITY PLATE .....	4
GENERAL DESCRIPTION .....	5
CCTS FEATURES .....	6
CCTS FEATURES FRONT .....	6
CCTS FEATURES REAR .....	8
CONFIGURATION .....	9
CCTS FEATURES IN DETAIL .....	10
EQUIPMENT MOUNTING .....	10
INTERFACE PINS AND SLIDE MECHANISM .....	12
CASTORS .....	13
UTILITY STORAGE BOXES .....	13
MAINS POWER CABLE .....	14
POWER DISTRIBUTION UNITS .....	14
ISOLATION TRANSFORMER .....	15
SETUP OF UNIT .....	16
FIRST TIME USE .....	16
<b>PART 2 USING THE CCTS</b>	
PRIOR TO USE CHECKS .....	17
CONNECTION TO BED .....	18
MANOEUVRING .....	22
CLEANING & DISINFECTING .....	23
DISCLAIMER .....	23
CLEANING .....	23
PROTECTIVE FINISH .....	23
STORAGE & TRANSPORTATION .....	24
PREPARATION FOR STORAGE .....	24
PREPARATION FOR TRANSPORTATION .....	24
ATTACH MEDICAL EQUIPMENT .....	25
CONNECTING MEDICAL EQUIPMENT .....	27



---

## CONTENTS CONTINUED

	PAGE
GAS CYLINDERS .....	28
SUCTION UNIT .....	28
MONITORS .....	29
DEFIBRILLATOR .....	29
IV INFUSION PUMP HOLDER .....	29
CABLE MANAGEMENT .....	29
SWITCH CCTS ON .....	30
<b>PART 3 UPKEEP</b>	
MAINTENANCE .....	31
GENERAL REQUIREMENTS .....	31
MAINTENANCE TASKS AND PERIODICITIES .....	31
PORTABLE APPLIANCE TESTING .....	31
PROVISION OF SPARES .....	32
AUTHORISED ANCILLARY EQUIPMENT .....	33
LUBRICATION .....	33
COMPONENT FITTING AND REMOVAL PROCEDURES .....	34
POWER DISTRIBUTION UNITS COVER .....	34
GAS CYLINDER STRAPS .....	36
FRONT CASTOR .....	37
REAR CASTOR & BRAKE ASSEMBLY .....	38
SLIDE MECHANISM BEARING BLOCKS .....	40
IV DRIP POLE .....	42
IV DRIP POLE COMPLETE WITH BRACKETS .....	42
SUPPORT TRAY .....	43
<b>PART 4 TROUBLESHOOTING</b>	
TROUBLESHOOTING .....	44
<b>ANNEX A SUPPLEMENTARY INFORMATION</b>	
MANUFACTURER'S ADDITIONAL INFORMATION .....	48
ACRONYMS .....	48
LIFE DATA .....	48
TECHNICAL DATA .....	48
PROTECTIVE FINISH .....	50
ELECTROMAGNETIC INTERFERENCE .....	50
DISPOSAL .....	50
DOCUMENT CONTENT .....	51
PROPRIETARY INFORMATION .....	51

## ANNEX B USER FEEDBACK FORM



# LIST OF FIGURES AND TABLES

## FIGURES

	PAGE
<b>PART 1 GENERAL INFORMATION</b>	
FIGURE 1.1 CCTS IDENTITY PLATE .....	4
FIGURE 1.2 CCTS ATTACHED TO BED .....	5
FIGURE 1.3 CCTS FRONT VIEW .....	6
FIGURE 1.4 CCTS REAR VIEW .....	8
FIGURE 1.5 EQUIPMENT MOUNTING FEATURES .....	10
FIGURE 1.6 MONITOR MOUNT .....	11
FIGURE 1.7 INTERFACE PINS AND SLIDE MECHANISM .....	12
FIGURE 1.8 CASTORS .....	13
FIGURE 1.9 UTILITY BOXES .....	13
FIGURE 1.10 MAINS POWER CABLE & QUICK RELEASE CONNECTOR .....	14
FIGURE 1.11 POWER DISTRIBUTION UNITS .....	14
FIGURE 1.12 ISOLATION TRANSFORMER AND THERMAL CIRCUIT BREAKER .....	15
FIGURE 1.13 CCTS DIRECTION OF TRAVEL .....	16
<b>PART 2 USING THE CCTS</b>	
FIGURE 2.1 FIT BED PINS .....	18
FIGURE 2.1 BED INTERFACE PIN ADAPTOR .....	19
FIGURE 2.2 LOCK LEVER POSITIONS .....	20
FIGURE 2.3 RELEASE BRAKES .....	20
FIGURE 2.4 INSERT BED PINS INTO HOLES IN BED .....	21
FIGURE 2.5 APPLY BRAKES .....	21
FIGURE 2.6 CCTS DIRECTION OF TRAVEL .....	22
FIGURE 2.7 SAFE WORKING LOADS .....	26
FIGURE 2.8 POWER DISTRIBUTION UNIT COVER .....	27
FIGURE 2.9 FIT/REMOVE GAS CYLINDERS .....	28
FIGURE 2.10 LAERDAL SUCTION UNIT MOUNT .....	28
FIGURE 2.11 SCREW CLAMP .....	29
FIGURE 2.12 THERMAL CIRCUIT BREAKER .....	30
<b>PART 3 UPKEEP</b>	
FIGURE 3.1 POWER DISTRIBUTION UNIT COVER - REMOVAL .....	34
FIGURE 3.2 POWER DISTRIBUTION UNIT COVER - FITTING .....	35
FIGURE 3.3 REMOVE/FIT GAS CYLINDER STRAPS .....	36
FIGURE 3.4 LAY UNIT ON ITS FRONT .....	37
FIGURE 3.5 REMOVE/FIT FRONT CASTOR .....	37
FIGURE 3.6 LAY UNIT ON ITS FRONT .....	38
FIGURE 3.7 REMOVE/FIT BRAKE LEVER .....	38



---

## FIGURE CONTINUED

	PAGE
FIGURE 3.8 REMOVE BRAKE LEVER ASSEMBLY .....	39
FIGURE 3.9 BRAKE ASSEMBLY ALIGNMENT .....	39
FIGURE 3.10 FITTING OF REAR BRAKED CASTORS .....	39
FIGURE 3.11 REMOVE/FIT SLIDE MECHANISM BEARING BLOCK .....	40
FIGURE 3.12 REMOVE/FIT BEARING BLOCK ASSEMBLY .....	41
FIGURE 3.13 REMOVE/FIT IV DRIP POLE .....	42
FIGURE 3.14 REMOVE/FIT IV DRIP POLE BRACKETS .....	42
FIGURE 3.15 REMOVE/FIT SUPPORT TRAY (THREE OPTIONAL POSITIONS) .....	43

## TABLES

### PART 1 GENERAL INFORMATION

TABLE 1.1 SYMBOLOGY .....	3
TABLE 1.2 IDENTITY PLATE SYMBOLS .....	4

### PART 2 USING THE CCTS

TABLE 2.1 MEDICAL EQUIPMENT LIST .....	25
TABLE 2.2 SAFE WORKING LOADS .....	26

### PART 3 UPKEEP

TABLE 3.1 MAINTENANCE TASKS AND PERIODS .....	31
TABLE 3.2 MAINTENANCE SPARES LIST .....	32
TABLE 3.3 ANCILLARY BRACKETS .....	33

### PART 4 TROUBLESHOOTING

TABLE 4.1 TROUBLESHOOTING GUIDE .....	45
---------------------------------------	----

### ANNEX A SUPPLEMENTARY INFORMATION

TABLE 5.1 ACRONYMS .....	48
TABLE 5.2 DIMENSIONS & MASS .....	48
TABLE 5.3 ENVIRONMENTAL CONDITION LIMITS .....	49
TABLE 5.4 SPECIFICATIONS .....	49



# PART 1 GENERAL INFORMATION

## 1.1 INTRODUCTION

This user manual has been put together by the manufacturer, Illustrious Healthcare Solutions (IHS). It will show you how to put your unit into operation and correctly use all its functions. This manual is an integral part of the Critical Care Transfer Stack (CCTS) and should be turned over to the new user should the CCTS be sold or transferred.

### 1.1.1 SUMMARY STATEMENT

The CCTS provides a means to maintain links to life support medical equipment whilst transporting a critical care patient, in a critical care bed, within a hospital. It consists of a frame on castors with facilities for attaching the variety of medical equipment that may be required.



**All users of the CCTS must read and understand this manual in full before using the equipment.**

### 1.1.2 DISCLAIMER

Illustrious Healthcare Solutions cannot be held responsible for damage, consequential damages or injuries caused by incorrect use/treatment or by negligent use or maintenance. The CCTS is designed for indoor use only and should not be used outside.

### 1.1.3 WARRANTY

Failure to follow these instructions may invalidate your warranty.

Unapproved modifications to the device are prohibited.

### 1.1.4 DOCUMENT NAVIGATION

Throughout the document are several links to associated information that can be activated when viewed electronically. All active links are coloured blue. Once the link is clicked a new location will be viewed. Return to the previous location is effected by clicking the appropriate blue  button at the bottom of the page.



---

## 1.2 GENERAL SAFETY

Safety while using the CCTS is paramount to protect patients, healthcare workers and the public from harm, please read and understand all safety related information, warnings and cautions before using the unit. It is recommended a risk assessment be done locally to identify any risk that might be mitigated.

CCTS is only to be used by trained and authorised personnel.

CCTS should not be used outside or on uneven surfaces.

Connecting electrical equipment to the power distribution units effectively leads to creating a medical electrical system and may result in a reduced level of safety. Any equipment installed / connected to the CCTS is outside of the boundary of the responsibility of IHS. The user is responsible for the system's safety in this configuration.

Operators should be trained in manual handling techniques and maintain good posture during all activities to avoid injury.

A minimum of two people are required to move the CCTS/bed combination.

A certain amount of effort is required to initially mobilise the CCTS/bed combination due to the castors potentially facing the incorrect direction of travel. To help overcome this, a slight sideways movement should be used to initialise the rotation of the castors to the new direction of travel.

Re-aligning castors whilst brakes are applied may lead to component damage. Ensure brakes are disengaged prior to re-alignment.

Before moving the CCTS/bed combination:

- Make sure interface pins are correctly located in the bed frame holes and top and bottom slide mechanisms are locked.
- Assess route to be taken for obstructions/accessibility. Check for suitable lighting, floor surfaces, open/closed doors, obstructions etc.
- Make sure all installed equipment is securely attached.
- Make sure brakes are disengaged.

When not attached to a bed, the CCTS can become unstable. Care should be taken when moving the CCTS, if possible it should be pushed/pulled sideways. Users should avoid leaving the unit unattended across a sloping floor.

Operators must not ride on the CCTS.









Due to the use of ferrous metals in the construction of the CCTS, it must not be used in a magnetic resonance imaging (MRI) room or where magnetic resonance is present.



## 1.2.1 SYMBOLOGY

Symbology used throughout these instructions for use and on the CCTS can be seen below.

*Table 1.1 Symbology*

Symbol	Meaning
	GENERAL WARNING SYMBOL. Risk to personnel specified by the supplementary text.
	WARNING ELECTRICITY. To warn of a hazard from electricity.
	SAFE WORKING LOAD. Refers user to instructions for use for the safe working load of a particular component.
	NOTE. Used to provide user with additional information, which is helpful but does not necessarily belong to the immediate subject.
	REFER TO INSTRUCTION MANUAL/BOOKLET. To signify that the instruction manual/booklet must be read.
	WASTE ELECTRICAL AND ELECTRONIC EQUIPMENT (WEEE). Indicates the product is classified as electrical and electronic equipment. The unit is to be passed to an appropriate collection point for the recycling of WEEE and disposed of in accordance with local regulations.
	BACK BUTTON. To return to your last position before you clicked on a hyper-link, when viewed electronically.
	Indicates protective earth (ground).
	WARNING LABEL ON POWER DISTRIBUTION UNITS. User must isolate power before cover is removed.





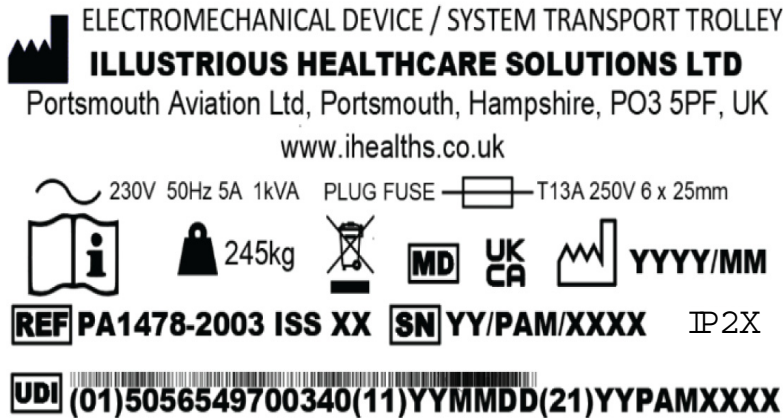

## 1.2.2 CCTS IDENTITY PLATE

The CCTS bears an identity plate as seen in [Fig 1.1](#). The definition of symbols shown on the plate, not detailed above, are described in [Table 1.2](#).



*Fig 1.1 CCTS Identity Plate*

*Table 1.2 Identity Plate Symbols*

Symbol	Meaning
	MANUFACTURER. Indicates manufacturer's name and address.
	DATE OF MANUFACTURE. Indicates date medical device was manufactured.
	CONSULT INSTRUCTIONS FOR USE. Indicates the need for user to consult instructions for use.
	UNITED KINGDOM CONFORMITY ASSESSED. Indicates the manufacturer or importer affirms the goods conformity with the UK health, safety, and environmental protection standards.
	TYPE OF FUSE. Indicates fuse rating and type.
	ALTERNATING CURRENT. Indicates voltage and power rating.
REF	CATALOGUE NUMBER. Indicates the manufacturer's catalogue number so that the medical device can be identified.
UDI	UNIQUE DEVICE IDENTIFIER. Indicates a carrier that contains unique device identifier information.
SN	SERIAL NUMBER. Indicates the manufacturer's serial number so that a specific medical device can be identified.
MD	MEDICAL DEVICE. Indicates the item is a medical device.
	All up mass of unit.
IP2X	INGRESS PROTECTION CODE. Protected against finger sized objects. Protection against water not specified.

## 1.3 GENERAL DESCRIPTION

During intra-hospital movement of critical care patients, it is essential that they are continued to be provided with life supporting medical equipment. To enable this requirement, the Critical Care Transfer Stack (CCTS) has been designed to provide a simple interface mechanism, to attach to a Critical Care Bed (bed) whilst supporting the variety of medical equipment. Fig 1.2 shows the CCTS attached to a bed with a selection of medical equipment in place.



**Personal Injury Hazard. To avoid a potential of an electric shock do no use CCTS if there is evidence of damage to electrical components.**



**Personal Injury Hazard. To avoid a potential of an electric shock, keep power cable, isolation transformer, power distribution units and equipment power cables away from water or other liquids. Do not plug cables in if wet.**

The CCTS is designed purely for movement and use indoors and is to be operated by a minimum of two people in the CCTS/bed combination. Medical equipment can be plugged into the CCTS power distribution units but it does not have its own power supply. Power to the power distribution units is provided via a mains power cable.

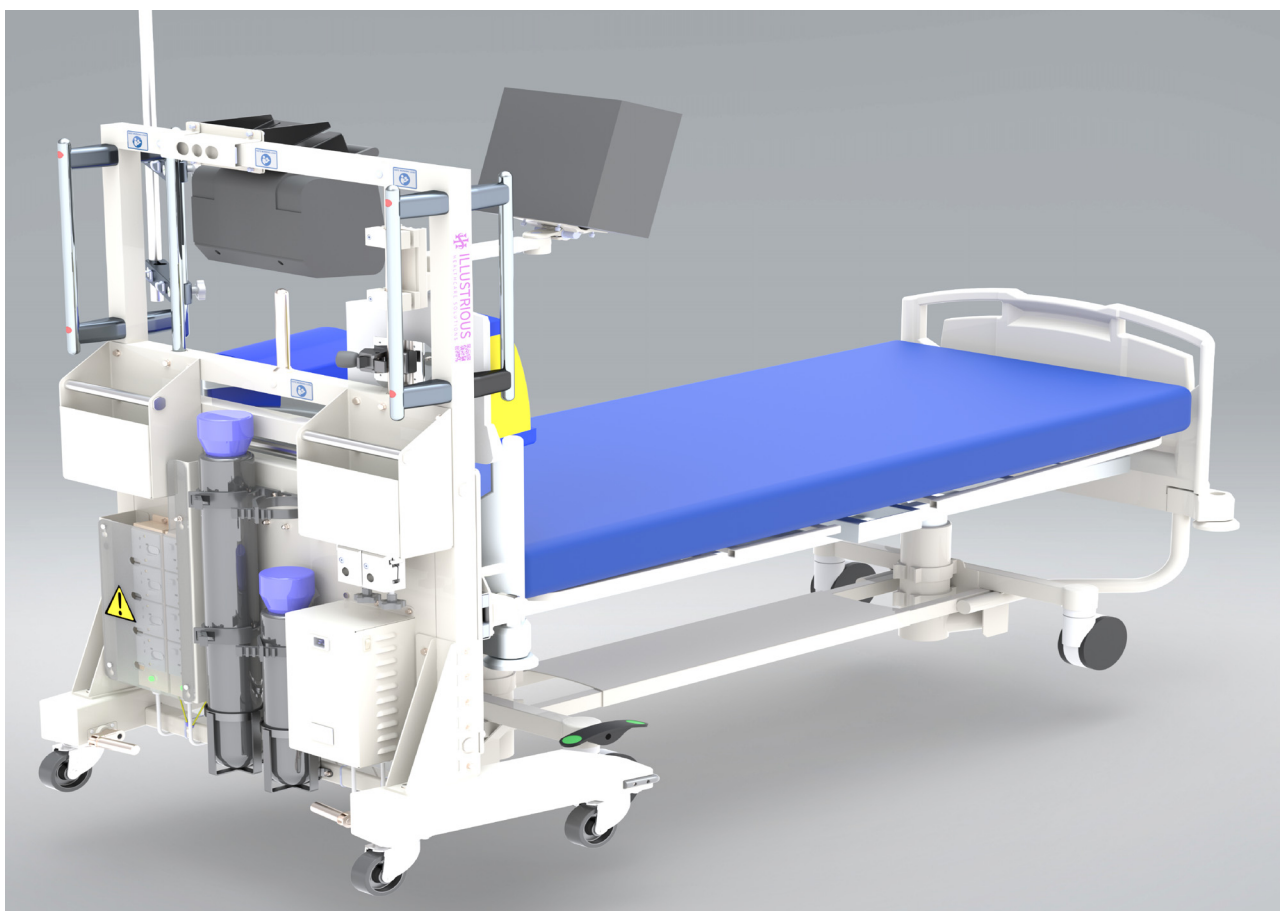

*Fig 1.2 CCTS Attached to Bed*



## 1.4 CCTS FEATURES

### 1.4.1 CCTS FEATURES FRONT

The CCTS is built as a frame on castors and consists of the features shown in [Fig 1.3](#) and [Fig 1.4](#).

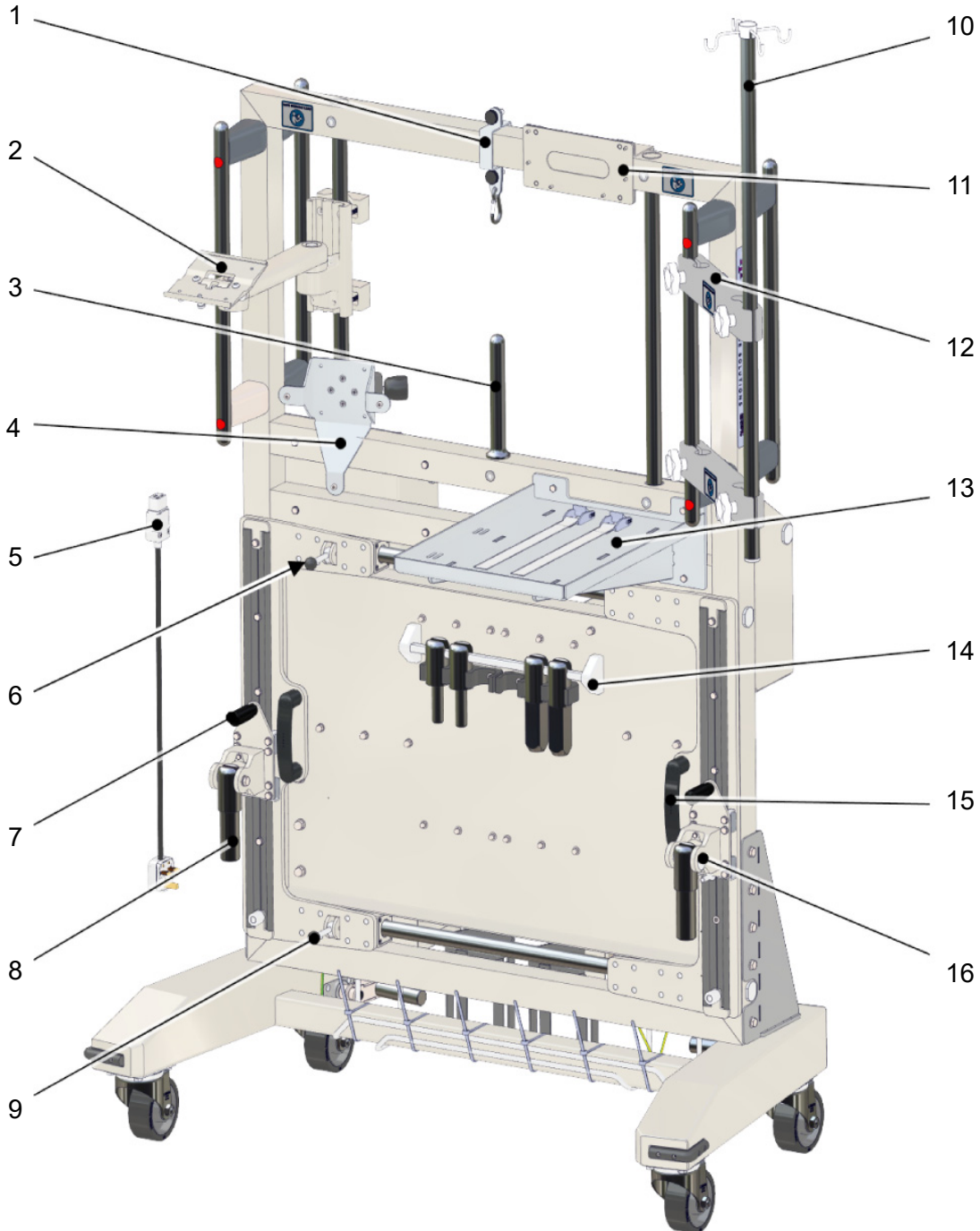

*Fig 1.3 CCTS Front View*

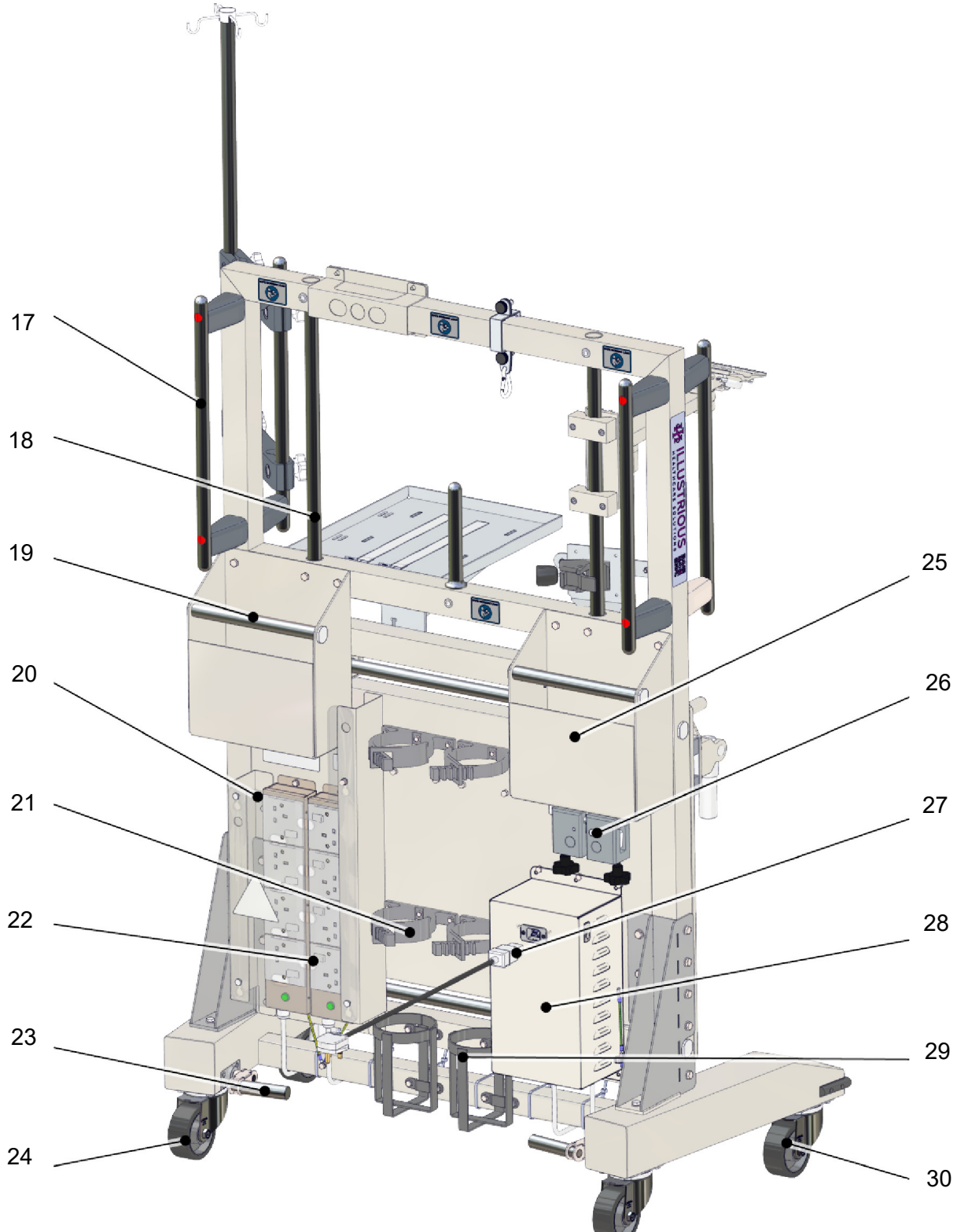

*Table 1.3 Key to Fig 1.3*

<b>Item</b>	<b>Description</b>	<b>Item</b>	<b>Description</b>
1	Hook Assembly	9	Mechanism Lock Lever
2	GCX Monitor Arm (Optional Extra)	10	IV Drip Pole
3	Equipment Post Short	11	Ventilator Interface Bracket
4	Laerdal Suction Unit Mount	12	IV Pole Bracket x2
5	Mains Power Cable	13	Support Tray
6	Mechanism Lock Lever	14	Interface Pins Stowage
7	Interface Handle x2	15	Mechanism Handle x2
8	Interface Pin x6	16	Interface Pin Mounts x2



## 1.4.2 CCTS FEATURES REAR



*Fig 1.4 CCTS Rear View*

Table 1.4 Key to Fig 1.4

Item	Description	Item	Description
17	Equipment Pole/Handle x4	24	Rear Castor x2
18	Inner Equipment Posts x2	25	Utility Storage Box x2
19	Manoeuvring Handle x2	26	Bed Adaptors
20	Power Distribution Unit Cover	27	Mains Power Cable Connector
21	Gas Cylinder Strap	28	Isolation Transformer
22	Power Distribution Unit	29	Gas Cylinder Holder x2
23	Brake Pedal x2	30	Front Castor x2

### 1.4.3 CONFIGURATION

The CCTS is designed to operate in the following modes:

- Configured with medical equipment (standalone):
  - Allows for charging of medical equipment internal batteries in this mode.
- Configured with medical equipment (attached to critical care bed):
  - Allows for charging of medical equipment internal batteries whilst stationary.
  - Allows continuation of treatment (under medical equipment internal batteries) whilst manoeuvring.

## 1.5 CCTS FEATURES IN DETAIL

### 1.5.1 EQUIPMENT MOUNTING

The CCTS is designed to support a variety of critical care medical devices. Mounting points are provided for monitors, ventilators, intravenous drivers, suction units, defibrillators and transfer bags on the upper frame. Vertical manoeuvring handles double as equipment poles to allow mounting of an intravenous driver, via brackets, at the IV pole.

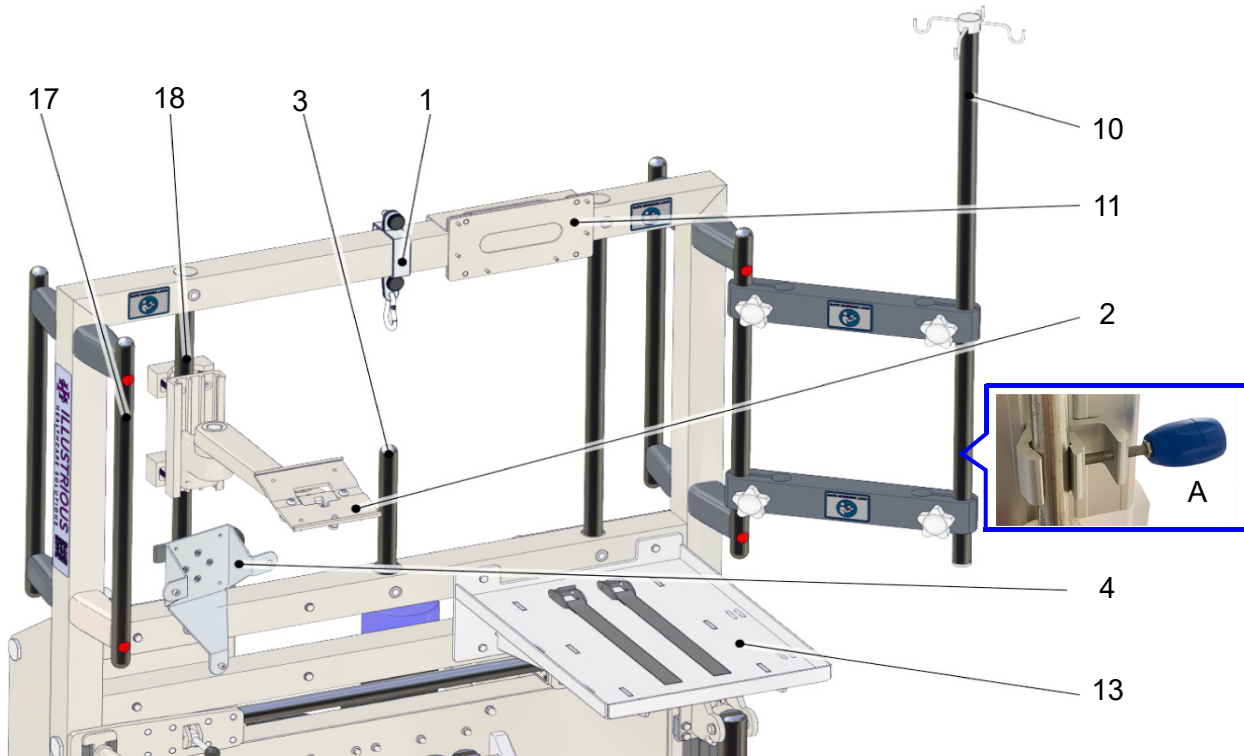

(Fig numbers here match those allocated in Fig 1.3 & Fig 1.4)

*Fig 1.5 Equipment Mounting Features*

*Table 1.5 Key to Fig 1.5*

Item	Description	Item	Description
17	Equipment Pole/Handle x4	11	Ventilator Interface Bracket
18	Inner Equipment Post x2	2	GCX Monitor Arm (Optional Extra)
3	Equipment Post Short	4	Laerdal Suction Unit Mount
1	Hook Assembly	13	Support Tray
10	IV Drip Pole	A	Clamp Example





**Personal Injury Hazard. Ensure that equipment being transported is attached properly. This prevents injury by objects falling while it is moving.**

Follow respective manufacturer's instructions to ensure equipment is mounted correctly and securely.

#### 1.5.1.1 Suction unit mount

A bracket is supplied with the CCTS to interface with a Laerdal suction unit (Fig 1.5 (4)). The bracket fits at the equipment posts and interfaces with a Laerdal suction unit wall bracket. The equipment post short (Fig 1.5 (3)) allows mounting of the suction unit to the rear of the CCTS.

#### 1.5.1.2 Ventilator mount

A ventilator interface bracket (Fig 1.5 (11)) is supplied with the CCTS to interface with a Draeger equipment holder for Oxylog or Hamilton T1 ventilators.

#### 1.5.1.3 Monitor mount

Monitors can be mounted on the equipment posts via GCX mount monitor arms (Fig 1.6).

The manufacturer is able to supply Draeger equipment holder and GCX mount monitor arms if required. Please contact manufacturer via email (see rear cover).

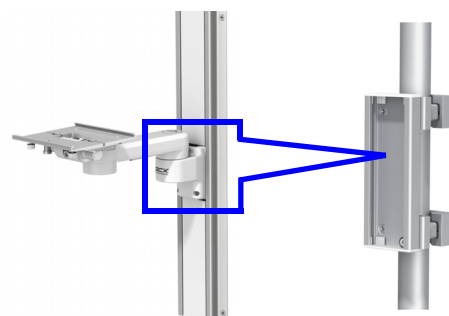

*Fig 1.6 Monitor Mount*

#### 1.5.1.4 Hook assembly

A hook assembly (Fig 1.5 (1)) is provided as an option for mounting patient transfer bags and is removable if not required.

#### 1.5.1.5 Support tray

A support tray (Fig 1.5 (13)) is supplied to mount a defibrillator, straps are included to ensure the defibrillator is mounted securely. The tray can be mounted in one of 3 positions (left, right and centre) on the frame. See para 3.2.8 for removal/fitting.

#### 1.5.1.6 Handles

On either side of the top frame, are two manoeuvring handles, which can also be used for mounting equipment with screw clamps (Fig 1.5 (17)).

#### 1.5.1.7 Gas cylinder holders and straps

At the base of the frame are two holders into which gas cylinders are placed. Each position has two rubber straps to hold the cylinders in place. See para 3.2.2 for strap removal/fitting.



## 1.5.2 INTERFACE PINS AND SLIDE MECHANISM

Interface pins, on adjustable slide mechanisms, are used to attach the CCTS to a bed. Various sizes of interface pin are available, depending upon the bed used. Round pins of 18.5mm & 32.5mm and square 27.5mm pins are supplied as standard<sup>1</sup>. The interface pin mounts are articulated to allow for any uneven floor surfaces during movement of the bed and CCTS combination.

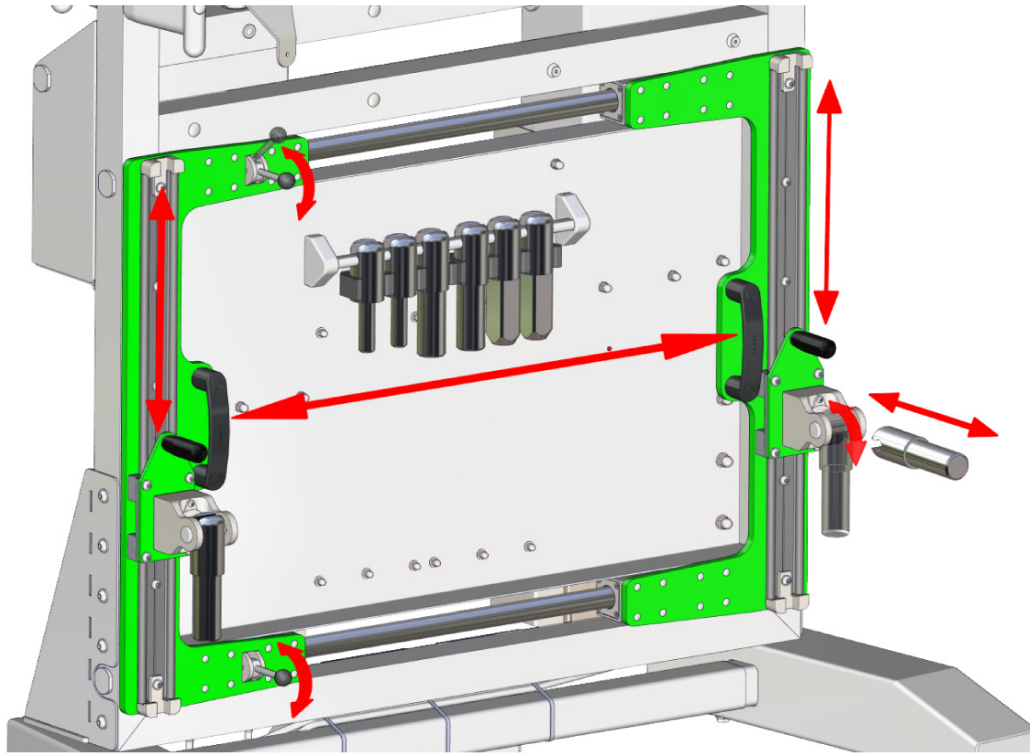

*Fig 1.7 Interface Pins and Slide Mechanism*

Interface pin mounts move up and down to provide height adjustment. The mechanisms move in and out to allow for different bed widths.

The left hand slide mechanism locks in place, once in the correct position.

---

*1. In the unlikely event that a bed is encountered that does not have a suitable pin, the supplier can provide a solution.*

### 1.5.3 CASTORS

Four swivel castors provide manoeuvrability. The two rear castors are fitted with brakes which are operated by foot pedals.

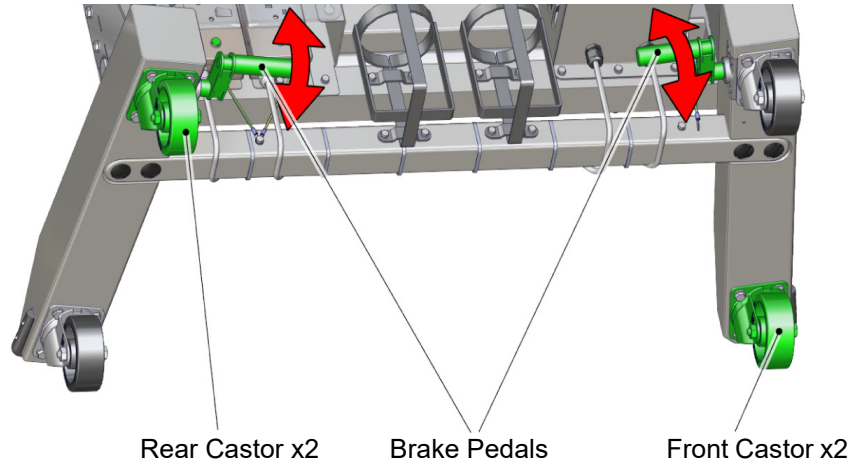

*Fig 1.8 Castors*

### 1.5.4 UTILITY STORAGE BOXES

Utility storage boxes provide storage for ancillary items. Handholds are incorporated to aid manoeuvring.

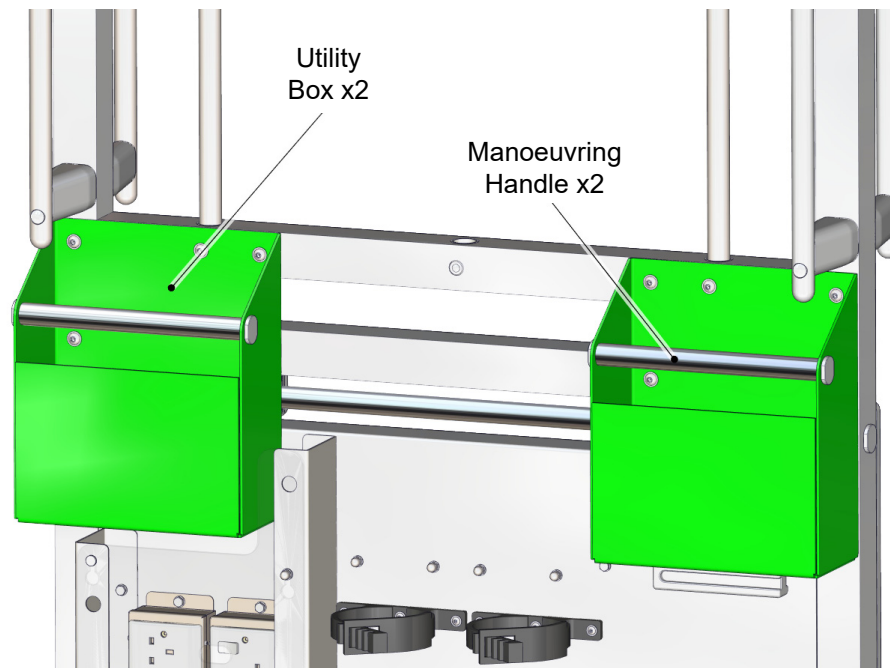
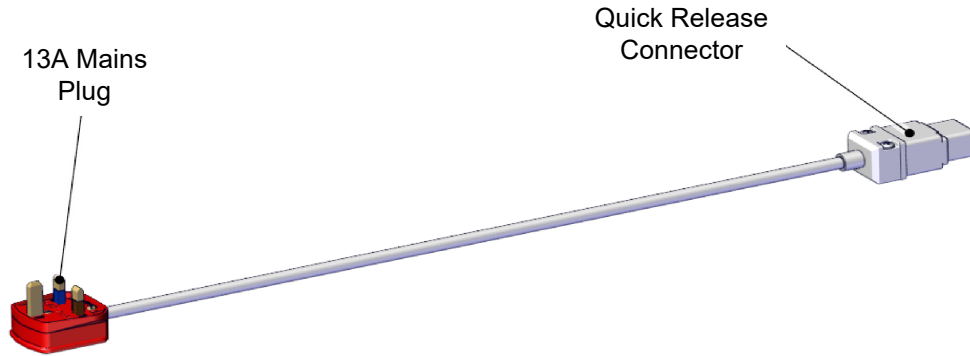

*Fig 1.9 Utility Boxes*



### 1.5.5 MAINS POWER CABLE

The mains power cable incorporates a quick release connector as a safety feature should the unit be inadvertently moved whilst still plugged into a wall socket.



*Fig 1.10 Mains Power Cable & Quick Release Connector*

### 1.5.6 POWER DISTRIBUTION UNITS

Two power distribution units, each with 4 switched sockets, provide connection for medical equipment when stationary and connected to mains power. Each power distribution unit has a green light to indicate mains power is connected and on. The power distribution units are guarded with a transparent cover to prevent tampering or connection of non-medical equipment. The cover is secured using a single 10mm nut (see [para 3.2.1](#)).

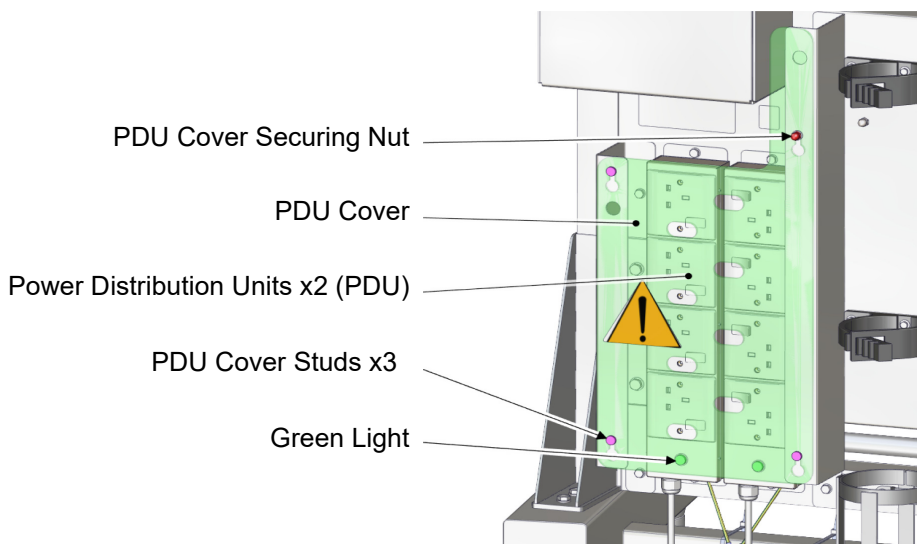

*Fig 1.11 Power Distribution Units*



**Note:**

When the CCTS/bed combination is moved, the unit is disconnected from the mains power so the internal batteries of the medical equipment will provide continuing power during patient intra-hospital transport.

### 1.5.7 ISOLATION TRANSFORMER

A 230V 1:1 isolation transformer is fitted to improve electrical safety by reducing risk of electric shock and earth leakage currents. The transformer also improves power quality and reduces electrical noise.

A thermal circuit breaker is fitted to provide overload protection. The breaker will trip when more than 5 amps is drawn.

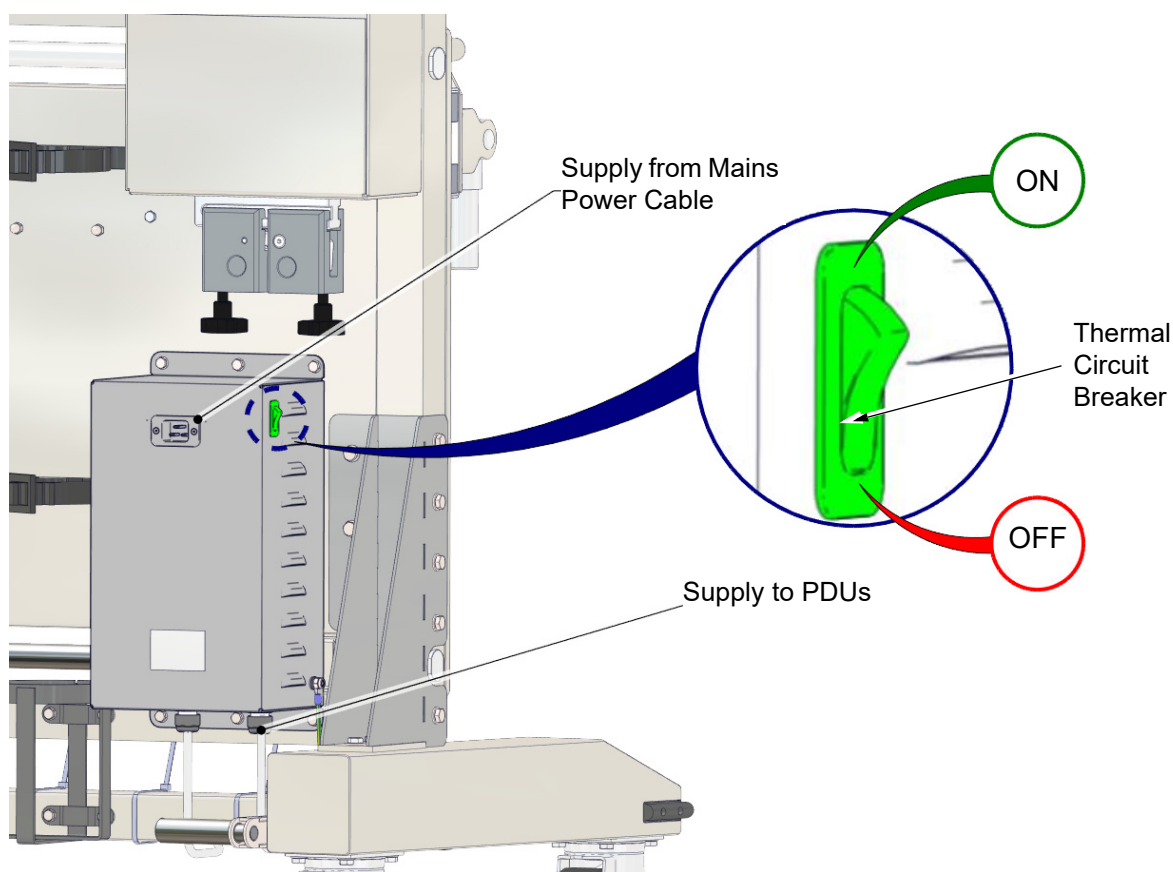

*Fig 1.12 Isolation Transformer and Thermal Circuit Breaker*



# PART 2 USING THE CCTS

## 2.1 SETUP OF UNIT



**Stability Hazard.** Do not push or pull the standalone CCTS forward or backward. Only move it by pushing/pulling sideways. There is a risk of standalone unit becoming unstable when pushing/pulling forward/backward, possibly causing injury to personnel.

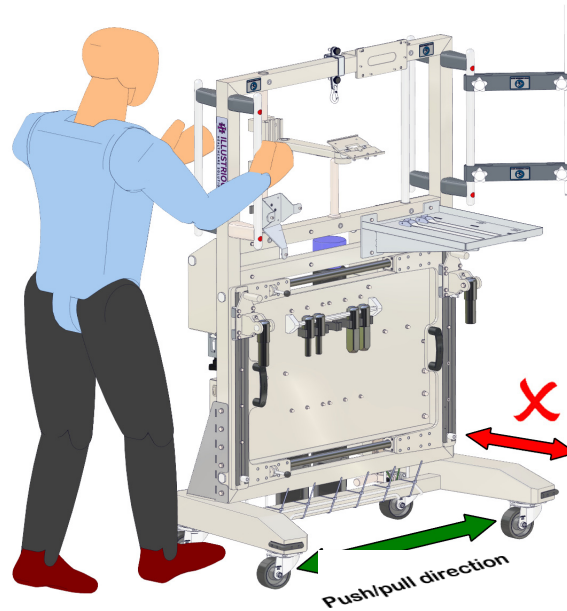

*Fig 2.1 CCTS Direction of Travel*



**Personal Injury Hazard.** There is a danger of electric shock if wires are exposed. Do not use if electrical cables are damaged.



**Equipment Damage Risk.** Make sure the power cable is disconnected from the wall socket before moving the CCTS.

### 2.1.1 FIRST TIME USE

- Unpack.
- Inspect for damage.
- Before using for first time, clean and disinfect in accordance with instructions in [para 2.3](#).
- Make sure CCTS is fully serviceable before use by completing the prior to use checks at [para 2.1.2](#).
- With assistance from suitably qualified personnel, attach medical equipment in accordance with the manufacturers' instructions (supplied separately).



Note:

Correct any problems before using CCTS or contact IHS for advice.

---

## 2.1.2 PRIOR TO USE CHECKS

Prior to use inspection should be done before initial use and then daily.



**Personal Injury Hazard. If there is any suspicion that the CCTS is not fit for purpose, do not use it. Seek advice from your supervisor.**



**Personal Injury Hazard. There is a possibility of entrapment when sliding the mechanisms. Take care when adjusting the interface mechanisms, to avoid trapped fingers.**

### 2.1.2.1 Prior to each use

Check the following:

- All fixings correctly fastened and secure.
- All moving parts free to move:
  - Mechanisms move freely up/down and in/out.
  - Lock levers prevent left hand mechanism moving when in down position.
  - Lock levers allow left hand mechanism to move when in up position.
  - Interface pin mounts rotate.
- Isolation transformer thermal circuit breaker is set to on.
- Castor brakes can be disengaged, and unit is free to move.
- Castor brakes can be engaged and prevent unit moving.
- Electrical safety:
  - Portable appliance test is in date.
  - Mains plug and quick release connector are undamaged and correctly attached.
  - No coloured wires visible where cables enter plug/transformer/distribution units.
  - No fraying, cuts, heavy scuffing or other damage to cables.
  - Cables correctly routed and secure/not trapped.
  - No signs of overheating, such as burn marks or staining.



## 2.1.3 CONNECTION TO BED

### 2.1.3.1 Preparation

- Remove footboard from bed.
- Select appropriate interface pin profile to match locating holes in bed.

### 2.1.3.2 Fit/remove pins to CCTS

- To fit pins, insert horizontally into pin mount/storage rail. Rotate pin to vertical to fix ([Fig 2.2](#)).
- To remove pins, raise to horizontal, slide out from pin mount/storage rail ([Fig 2.2](#)).

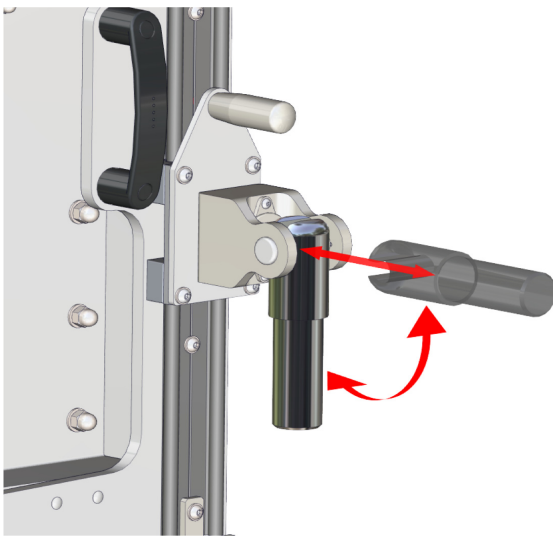

Pin Storage Rail

*Fig 2.2 Fit Bed Pins*



### 2.1.3.3 Bed interface pin adaptor

Some beds (Legacy bi-lateral turning complex care bed), require an adaptor (Fig 2.3) to interface the pins with the bed. This is a clamp which locks onto the rail at the foot of the bed into which the interface pins engage.

- Remove adaptors from stowage.
- Fit adaptors to rail on bed approximately 25mm from ends, tighten thumb wheel.
- Continue attaching CCTS as para 2.1.3.4 using the adaptors to engage the interface pins.

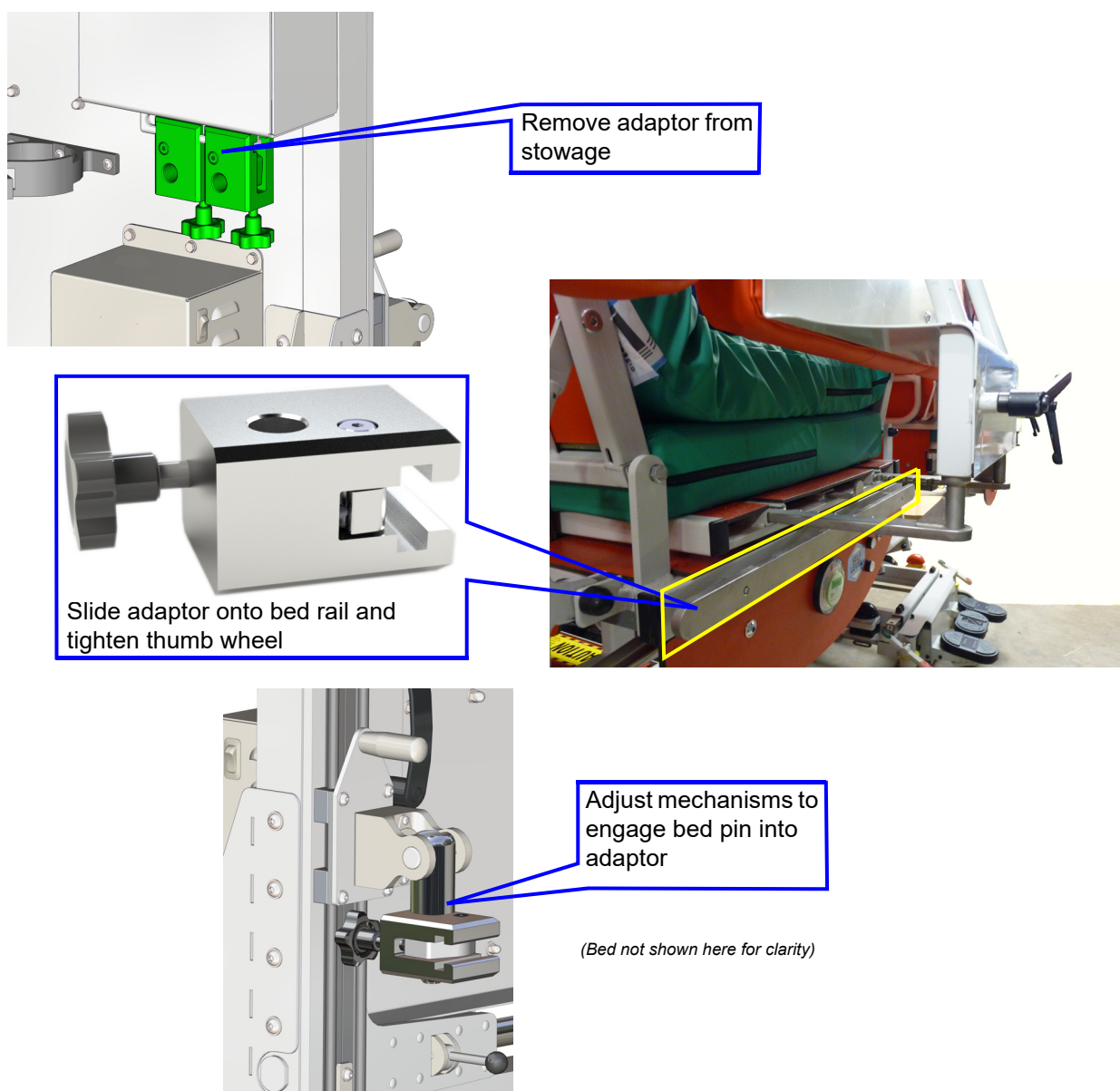

Fig 2.3 Bed Interface Pin Adaptor

### 2.1.3.4 Unlock left hand mechanism

- Move the 2 levers, located on the top and bottom of left hand slide mechanism, to the unlocked position as seen in [Fig 2.4](#).



Note:

The right hand slide mechanism does not lock, it becomes fixed once the CCTS is connected to the bed and the left hand lock levers are set to locked.

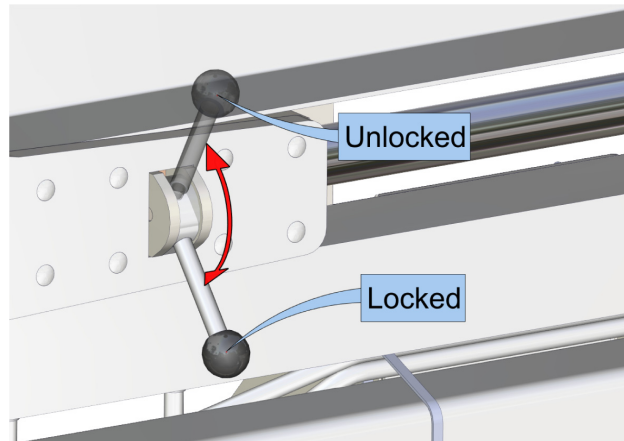

*Fig 2.4 Lock Lever Positions*

### 2.1.3.5 Release CCTS brakes

- Lift brake pedals with foot to disengage ([Fig 2.5](#)).

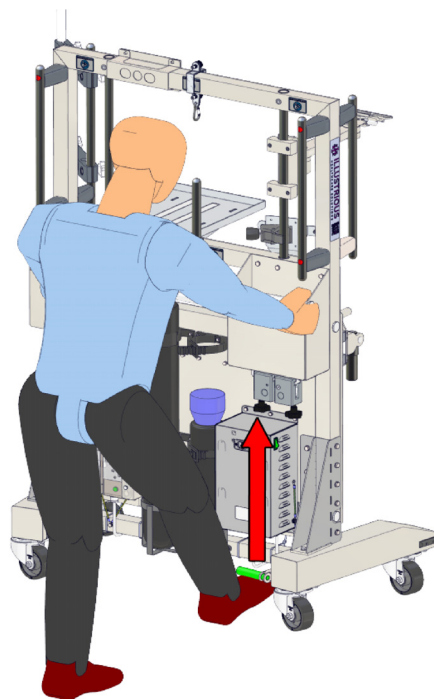

*Fig 2.5 Release Brakes*

### 2.1.3.6 Attachment to bed



**Personal Injury Hazard.** There is a possibility of entrapment while attaching CCTS to the bed. Do not stand between bed and CCTS during attachment. Keep hands and feet clear of interfaces and castors while moving CCTS.

- Push CCTS to foot of bed and insert pins into bed frame locating holes (Fig 2.6), one at a time, moving interface mechanisms in/out, up/down as necessary.
- Once attached, align CCTS centrally about bed, there is a centreline marked on the CCTS to assist.

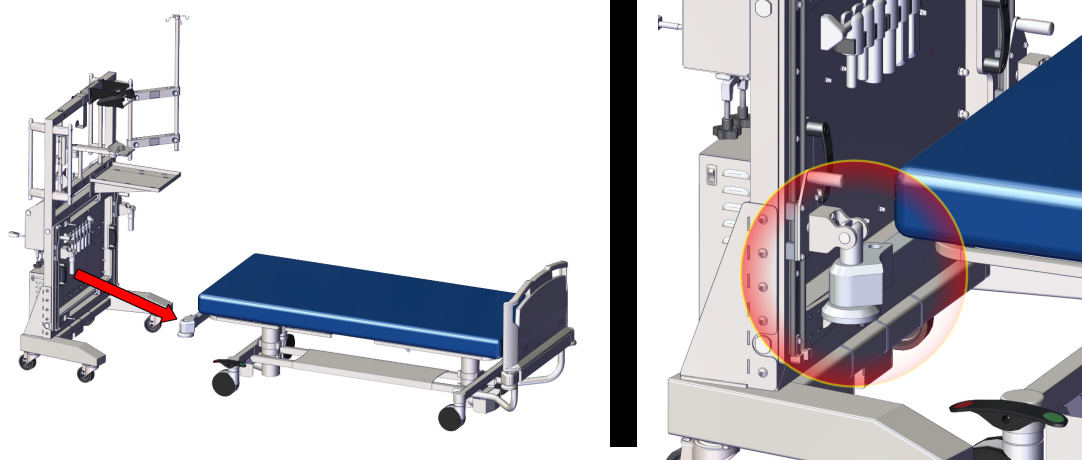

*Fig 2.6 Insert Bed Pins into Holes in Bed*

### 2.1.3.7 Lock left hand mechanism

- Move the 2 levers, located at the top and bottom of left hand slide mechanism, to locked position as seen in Fig 2.4.
- If necessary apply brakes by pushing down on pedals with foot (Fig 2.7).



Note:

Operator has the option to release brakes on bed and use CCTS brakes for control.

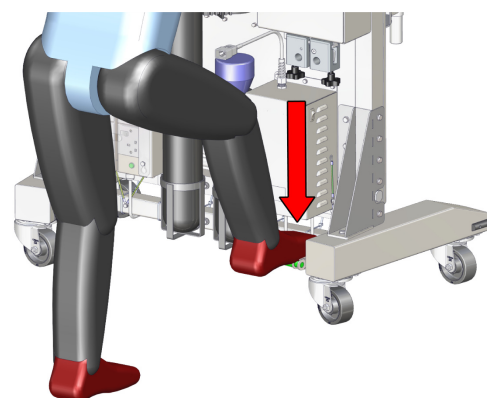

*Fig 2.7 Apply Brakes*

### 2.1.3.8 Detach from bed

- Lift bed pin interface mechanisms to withdraw pins from bed frame.
- Manoeuvre bed or CCTS as required.
- Replace bed pins on pin storage rail.

## 2.2 MANOEUVRING



**Personal Injury Hazard.** There is a risk of the CCTS becoming top heavy when loaded with equipment. To prevent toppling, only move standalone CCTS by pushing/pulling sideways.



**Personal Injury Hazard.** The CCTS mass is 200kg without medical equipment installed and up to 245kg with medical equipment loaded. Operators should be trained in manual handling techniques.



**Personal Injury Hazard.** Take care when manoeuvring the unit while transfer bags are attached. Operator vision should not be impaired. If unavoidable, users should put controls in place locally to mitigate the possibility of an accident.



**Personal Injury Hazard/Equipment Damage Risk.** CCTS is of metallic construction. Do not use near magnetic resonance imaging (MRI) equipment.



**Equipment Damage Risk.** Re-aligning castors whilst brakes are applied may lead to component damage. Ensure brakes are disengaged prior to alignment.

Before moving the CCTS/bed combination:

- Make sure interface pins are correctly located in the bed frame holes and top and bottom slide mechanisms are locked.
- Assess route to be taken for obstructions/accessibility. Check for suitable lighting, floor surfaces, open/closed doors, obstructions etc.
- Make sure all installed equipment is securely attached.
- Make sure brakes are disengaged.

Before mobilising the CCTS make sure all attached equipment is secured safely or removed. A dynamic risk assessment of the route should be undertaken prior to manoeuvring. A minimum of two people must be used to move CCTS/bed combination.

There may be occasions when it will be necessary for some departments to mount a transfer bag on the CCTS. Space on the CCTS dictates that the only position for this bag is at the rear on the upper frame. In these circumstances the field of vision could be obscured. It is recommended a dynamic risk assessment be done to ensure vision is not impaired.



Note:

A certain amount of effort is required to initially mobilise the CCTS/bed combination due to the castors potentially facing the incorrect direction of travel. To assist in moving the unit in the opposite direction, a slight sideways movement can be used to initialise the rotation of the castors to the new direction of travel.

When moving the unit on its own, care should be taken to push/pull it sideways. Users must control the speed when in motion and should not leave it unattended on a slope.

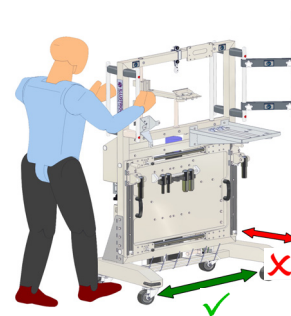

Fig 2.8 CCTS Direction of Travel

---

## 2.3 CLEANING & DISINFECTING



**Personal Injury Hazard.** There is a danger of electric shock if electrical equipment gets wet. Do not get water/fluids in electrical equipment. Make sure CCTS is disconnected from mains prior to cleaning.



**Equipment Damage Risk.** Permanent damage to the surface finish could be caused by strong chemicals and solvents. Use all chemicals and solvents in accordance with manufacturers' instructions



Note:

Testing of any cleaning solution on an inconspicuous area of the device to verify compatibility is recommended.

### 2.3.1 DISCLAIMER

IHS make no claims regarding the efficacy of chemicals or processes as a means for controlling infection. Consult your hospital's infection control officer or epidemiologist.

### 2.3.2 CLEANING

The CCTS can be cleaned and disinfected to maintain hygiene, using sanitising anti-bacterial wipes and/or chlorine based disinfectant solution, in accordance with usual cleaning regimes.

- Make sure mains power is disconnected.
- Do not use steel wool or other abrasive material.
- Avoid exposing the device to cleaning agents for long periods by wiping off using a water dampened cloth.
- Dry all equipment thoroughly after cleaning.



Note:

Make sure the unit is completely dry after any cleaning process to avoid possibility of corrosion or residue build up that may hinder the movement of the slide mechanisms.

### 2.3.3 PROTECTIVE FINISH

The unit is protected with a powder coating paint finish that incorporates antimicrobial properties. This type of finish aids cleaning and hygiene.



---

## 2.4 STORAGE & TRANSPORTATION

The CCTS is designed for indoor use only, the environmental condition limits detailed at [Table 5.4](#) should be observed.

### 2.4.1 PREPARATION FOR STORAGE

When the CCTS is put into store it is important to make sure that all components belonging to the unit are present and secure. Medical equipment can remain fitted, however it is recommended that this is removed and stored as suggested by its own instructions.



Note:

If medical equipment is to remain fitted, make sure all retaining clamps and brackets are secure.

- Make sure bed pins, 6off, are correctly stowed and clipped into pin storage rail.
- Make sure adaptor clamps for Legacy bed are stowed in their storage position under right hand utility storage box.
- Make sure slide mechanisms are unlocked (lock levers fully up).
- Fold IV drip pole inwards to rest against front of top frame.
- Tidy any electrical cables to ensure they do not become damaged, tangled or lost.

### 2.4.2 PREPARATION FOR TRANSPORTATION

In the unlikely event that the unit has to be returned to manufacturer for repair, it will require packing to allow protection and help prevent damage during transport.

Contact the manufacturer via email (see rear cover) to arrange return shipping instructions.



**Personal Injury Hazard. The CCTS mass is 200kg without medical equipment loaded and up to 245kg with medical equipment loaded. Operators should be trained in manual handling techniques.**

- Remove all medical equipment if still fitted, and stow safely.
- Remove any medical equipment brackets and clamps (refer to manufacturers' instructions).
- Loosen IV drip pole thumb wheels, 2off, and lower to minimum height, tighten thumb wheels.
- Loosen IV drip pole bracket thumb wheels, 2off, and fold flat against upper frame, tighten thumb wheels.
- Make sure bed pins, 6off, are correctly stowed and clipped into pin storage rail.
- Make sure adaptor clamps for Legacy bed are stowed in their storage position under right hand utility storage box.

## 2.5 ATTACH MEDICAL EQUIPMENT



**Personal Injury Hazard.** Interfacing components have weight limitations, refer to [Table 2.2](#) for Safe Working Loads (SWL). Overloading arms, poles, posts, trays or brackets could lead to component failure and subsequent injury to personnel.



**Personal Injury Hazard.** When medical equipment is mounted do not route cables outside of the CCTS frame. They may become a snagging hazard and pull equipment from the mount during patient intra-hospital transport.

Attach any required medical equipment to the equipment poles and support tray in accordance with respective manufacturers' instructions.

Equipment that can be used on the unit is listed in, but not limited to, [Table 2.1](#). Safe working loads, as detailed in [Table 2.2](#) and [Fig 2.9](#), must be observed to prevent overloading.

Reusable cable ties are provided with the unit to aid in cable management.

*Table 2.1 Medical Equipment List*

Description	Make
Ventilator	Hamilton T1 Oxylog
Monitor	Carescape B450 Carescape B650 Carescape One
Defibrillator	Zoll R series
Suction Unit	Laerdal Suction Unit
IV Infusion Pump Holder	Link Agilia Link+ Agilia
Oxygen Cylinder	Size E Size CD
Patient Transfer Bag	

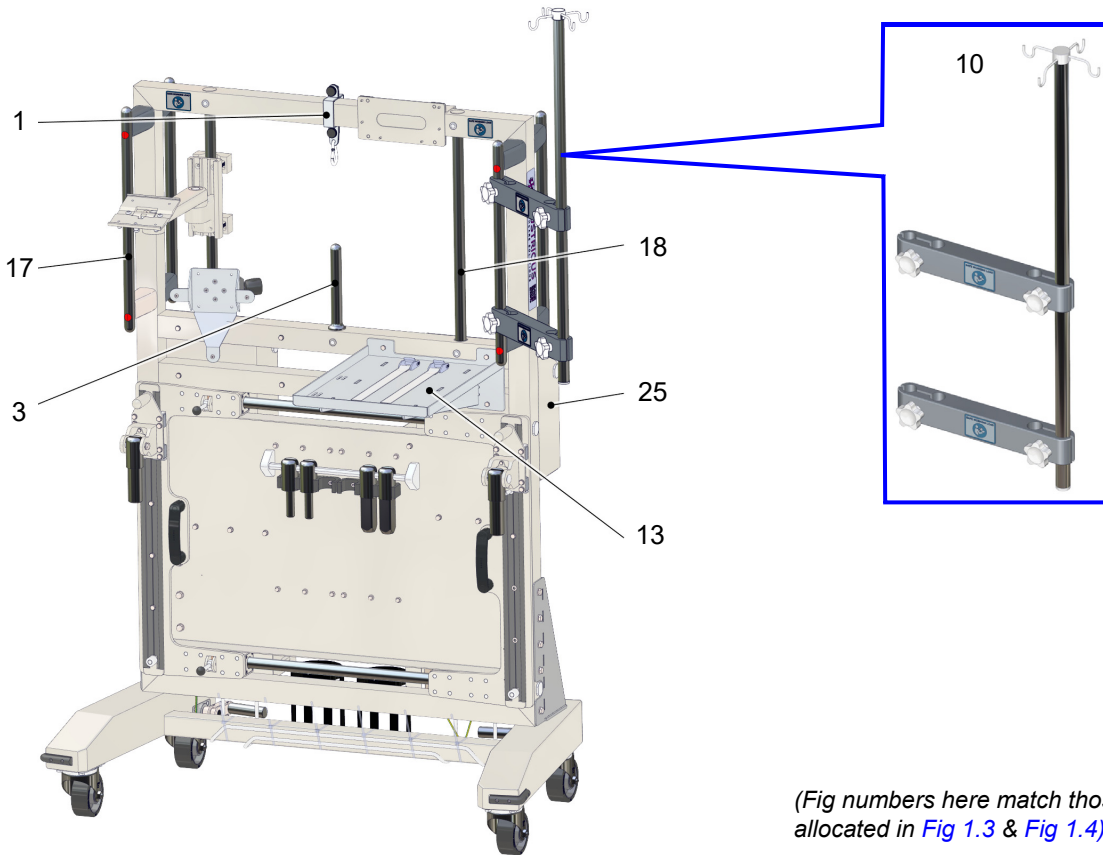

(Fig numbers here match those allocated in Fig 1.3 & Fig 1.4)

**Fig 2.9 Safe Working Loads**

**Table 2.2 Safe Working Loads**

Item	Component	SWL	Suggested Use
1	Hook Assembly	10kg	Transfer Bag
17	Equipment Pole/Handles x4	40kg	IV Infusion Pump Holder
3	Equipment Post	10kg	Suction Unit
10	IV Drip Pole	30kg	IV Bags
18	Inner Equipment Posts x2	25kg	Suction Unit/Monitors
25	Utility Storage Boxes x2	10kg	Ancillaries
13	Support Tray	10kg	Defibrillator



## 2.5.1 CONNECTING MEDICAL EQUIPMENT



**Personal Injury Hazard.** Interfacing components have weight limitations, refer to [Table 2.2](#) for Safe Working Loads (SWL). Overloading arms, poles, posts, trays or brackets could lead to component failure and subsequent injury to personnel.



**Personal Injury Hazard.** Personnel may be injured by incorrectly fitted equipment falling from the device. Fitting of equipment must be completed by a suitably qualified person.

- Make sure CCTS mains power cable is disconnected from wall socket.
- Attach medical equipment to CCTS securely using correct interfacing brackets.
- Remove power distribution unit cover (see [para 3.2.1.2](#)).
- Plug equipment into power distribution unit.
- Fit power distribution unit guard cover (see [para 3.2.1.2](#)).
- Connect CCTS mains power cable to wall socket.

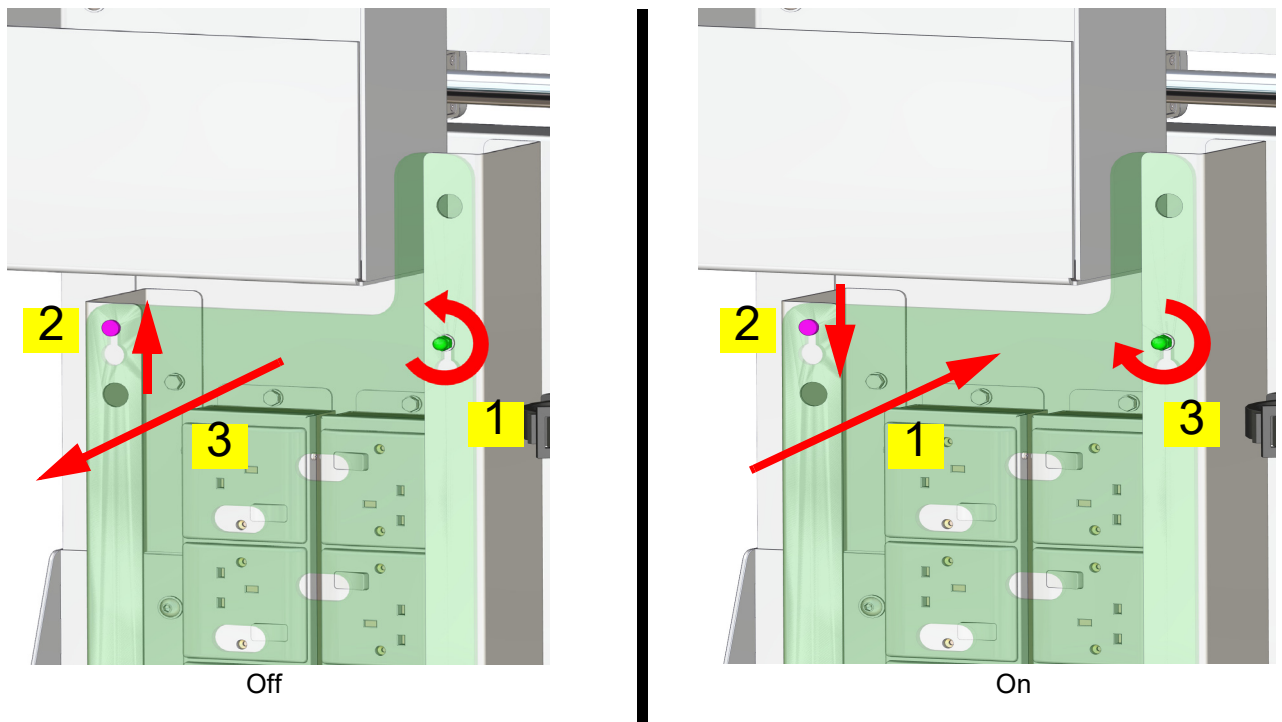

*Fig 2.10 Power Distribution Unit Cover*



## 2.5.2 GAS CYLINDERS



**Personal Injury Hazard.** Cold burns could occur from release of compressed gas. Take care when gas cylinders are connected/disconnected.



**Personal Injury Hazard.** Personnel may be injured by incorrectly fitted equipment falling from the device. Fitting of equipment must be completed by a suitably qualified person.

### 2.5.2.1 Fit

- Unfasten straps.
- Place gas cylinder in holder (Fig 2.11).
- Fasten straps securely round cylinders.
- Connect gas cylinder hose.

### 2.5.2.2 Remove

- Disconnect gas cylinder hose.
- Unfasten straps.
- Lift gas cylinder out of holder (Fig 2.11).

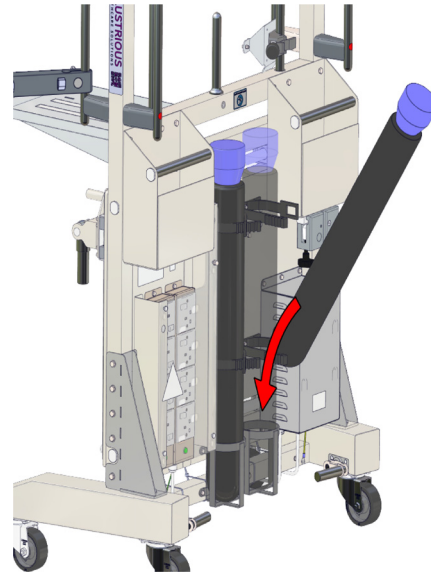

Fig 2.11 Fit/Remove Gas Cylinders

## 2.5.3 SUCTION UNIT

CCTS is delivered with the dedicated mounting bracket to receive the Laerdal suction unit wall bracket. The suction unit can be mounted on any of the equipment posts.

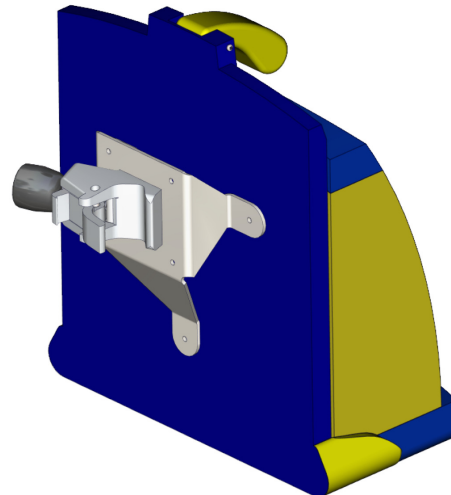

Fig 2.12 Laerdal Suction Unit Mount

---

## 2.5.4 MONITORS

Monitors can be mounted on the equipment posts using a GCX clamp and monitor arm. GCX clamp and monitor arms are not provided as standard but can be supplied by IHS on request. To fit/remove the GCX clamp and monitor arm proceed as described in GCX instructions.

## 2.5.5 DEFIBRILLATOR

A defibrillator can be fitted on the support tray and held in place with the adjustable straps.

## 2.5.6 IV INFUSION PUMP HOLDER

The IV infusion pump holder can be mounted on the IV drip pole, using the screw clamps on the pump holder itself.



*Fig 2.13 Screw Clamp*

## 2.5.7 CABLE MANAGEMENT

When mounting medical equipment the cables must be kept tidy and routed such that they will not become snagged during patient intra-hospital transport. Reusable cable ties are provided to secure cables to the frame.

## 2.5.8 SWITCH CCTS ON



**Equipment Damage Risk.** Continuous resets of the thermal circuit breaker could result in equipment damage. If the thermal circuit breaker on the transformer continually trips, remove the CCTS from use and get a suitably qualified person to investigate the fault.

- Make sure thermal circuit breaker on isolation transformer is set to 'on', (switch in up position) (Fig 2.14).
- Check mains power cable attached to unit at transformer.
- Attach mains power cable to wall outlet socket, switch on.
- Check power distribution unit green 'mains on' indicators illuminate.
- Set power distribution unit switches to on as required.
- In the event of a power failure, check thermal circuit breaker on isolation transformer (Fig 2.14), reset if required.

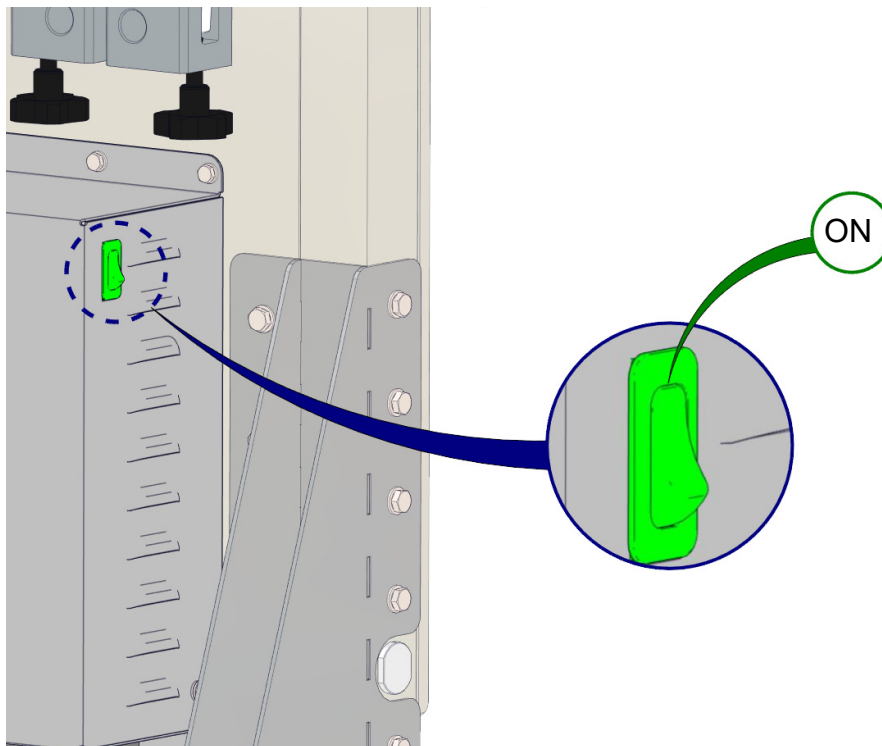

*Fig 2.14 Thermal Circuit Breaker*



## 3.1 MAINTENANCE

### 3.1.1 GENERAL REQUIREMENTS



**Personal Injury Hazard. Do not undertake any maintenance on this product unless you are suitably qualified and experienced. Any attempt to maintain or repair the unit when not competent may lead to injury of personnel.**

In order to maintain safety it is necessary to keep the CCTS in good working order, the tasks and periodicities at [Table 3.1](#) are recommended as minimum maintenance activities.



Note:

Spares for 5-yearly (mid-life) maintenance can be provided for suitably qualified personnel to undertake tasks locally. Alternatively, the manufacturer can provide a support engineer to undertake the maintenance and survey the unit (see rear cover for contact details).

### 3.1.2 MAINTENANCE TASKS AND PERIODICITIES

*Table 3.1 Maintenance Tasks and Periods*

Service Task	Periodicities	Link to Instructions	Remarks
Prior to use checks.	a. Before use. b. After maintenance. c. When removing from storage.	<a href="#">para 2.1.2</a>	To be carried out by healthcare professionals using the unit.
Cleaning/disinfecting.	Daily or post treatment.	<a href="#">para 2.3</a>	Whichever is shorter.
Portable appliance testing.	Prior to initial use, then in line with local procedures.	<a href="#">para 3.1.3</a>	To be carried out by a suitably qualified engineer.
Replace gas cylinder straps.	5 yearly.	<a href="#">para 3.2.2</a>	See note above.
Replace front castors.	5 yearly.	<a href="#">para 3.2.3</a>	See note above.
Replace rear castors & brake assemblies.	5 yearly.	<a href="#">para 3.2.4</a>	See note above.
Replace bearing block assemblies.	5 yearly.	<a href="#">para 3.2.5</a>	See note above.

### 3.1.3 PORTABLE APPLIANCE TESTING

It is recommended that a portable appliance test be done prior to first use and then in line with local procedures.



### 3.1.4 PROVISION OF SPARES



**Personal Injury Hazard. Continued use of CCTS with broken components may cause a danger to personnel or further damage to the unit. Remove the CCTS from use until the defect is rectified.**

In normal use there will be no requirement for spares however, if a component or part becomes damaged during use it will need replacing. In this instance the unit must be removed from use until it is rectified.

Other spares can be ordered in the event of damage or loss. Although replacement procedures may not be detailed in this manual, if necessary, the manufacturer can advise via email (see rear cover).

*Table 3.2 Maintenance Spares List*

Maintenance Spares	Ref No.	Quantity
5 Yearly spares kit:	130958	1
• Gas Cylinder Strap	130786	4
• Rear Braked Castor	130956	2
• Forward Castor	130957	2
• Brake Assembly	130697	2
• Locking Bearing Block	130291	2
• Bearing Block	130301	2
Other Spares	Ref No.	Quantity
Mains Power Cable	130758	1
IV Drip Pole	130289	1
IV Pole Bracket	130755	2
Hook Assembly	131139	1
Laerdal Suction Unit Bracket	130508	1
Bed Pin 18.5mm round	127910	2
Bed Pin 32.5mm round	127909	2
Bed Pin 27.5mm square	127908	2
Support Tray	130531	1
• Support Tray Straps	130772	2
Power Distribution Unit (outer) (PDU)	130749	1
Power Distribution Unit (inner) (PDU)	130748	1
PDU Cover complete with:	130736	1
• PDU Cover Nut, M6	130793	1
Corner Bumper	131036	2



### 3.1.5 AUTHORISED ANCILLARY EQUIPMENT

The CCTS has been designed for use with optional ancillary equipment, parts are available from the manufacturer as detailed in [Table 3.3](#), please contact manufacturer via email (see rear cover).

*Table 3.3 Ancillary Brackets*

Description	Manufacturer	Ref No.
7" Channel with clamp interface for 19-51mm dia post/pole.	GCX	130492
8" M Series pivot arm with slide in mounting plate.	GCX	130497
12" M series pivot arm with slide in mounting plate.	GCX	130493
6" Fluted post for M series pivot arm.	GCX	131028
9" Fluted post for M series pivot arm.	GCX	131029
12" Fluted post for M series pivot arm.	GCX	130494
Equipment holder.	Draeger	130961

### 3.1.6 LUBRICATION

No lubrication is required on the CCTS.



## 3.2 COMPONENT FITTING AND REMOVAL PROCEDURES

Components that can be replaced when damaged, are identified in [Table 3.2](#). Procedures to complete these tasks are below. Spares, where needed, can be ordered from the manufacturer, please contact manufacturer via email (see rear cover).



**Personal Injury Hazard.** The CCTS mass without medical equipment loaded is 200kg. Use suitable numbers of people to manoeuvre the unit.



**Personal Injury Hazard.** To avoid a potential of an electric shock, switch off and disconnect mains power prior to undertaking work on the unit.

### 3.2.1 POWER DISTRIBUTION UNITS COVER

To enable medical equipment to be connected electrically to the CCTS, it will be necessary to remove the cover from the power distribution units.

*Table 3.4 Tools Required*

Description	Qty
Spanner 10mm	1

#### 3.2.1.1 Removal

- Loosen, but do not remove, M6 dome nut (1).
- Slide cover upwards (2) so that fixings align with lower part of keyhole slots and pull cover away (3) ([Fig 3.1](#)).

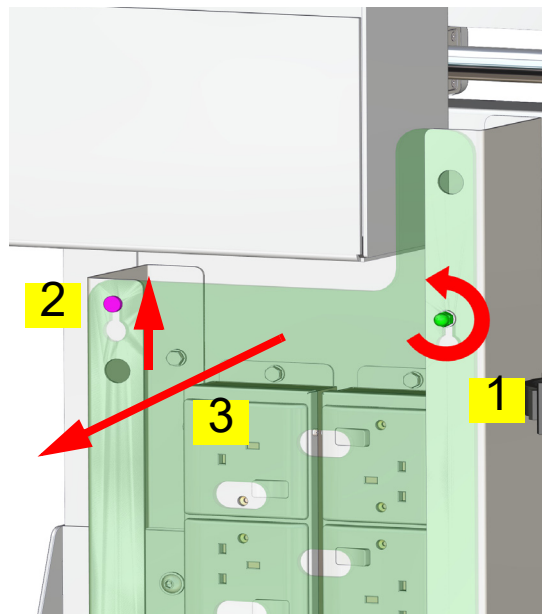

*Fig 3.1 Power Distribution Unit Cover - Removal*



### 3.2.1.2 Fitting

- Make sure all connected equipment cables are routed in the space between the side of the cover mount bracket and PDU, and not getting trapped under the cover as it is replaced.
- Align cover keyhole slots over fixings (1), and lower into position, engaging 4off keyhole slots (2).
- Make sure M6 washer and M6 dome nut are on outside face of cover, and tighten (Fig 3.2).



**Equipment Damage Risk. Do not over-tighten dome nut on cover.**

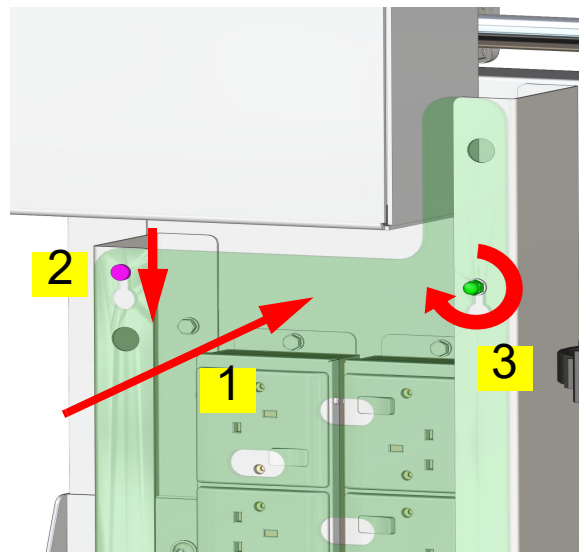

*Fig 3.2 Power Distribution Unit Cover - Fitting*



## 3.2.2 GAS CYLINDER STRAPS

*Table 3.5 Tools Required*

Description	Qty
Spanner/socket 8mm	2

### 3.2.2.1 Removal

- Remove any gas cylinders.
- Remove 3off M5x16 hex head bolts and dome nuts complete with washers, holding strap in place (Fig 3.3).

### 3.2.2.2 Fitting

- Locate new strap in position and secure with 3off M5x16 hex head bolts and dome nuts complete with washers.
- Tighten (Fig 3.3).

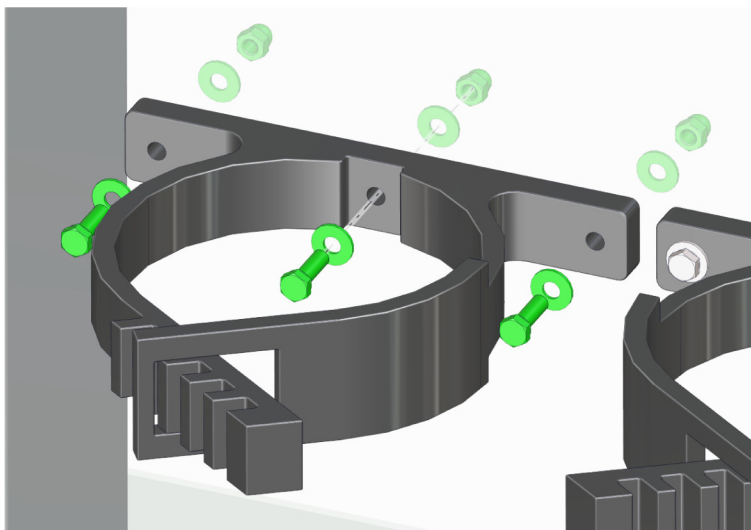

*Fig 3.3 Remove/Fit Gas Cylinder Straps*

### 3.2.3 FRONT CASTOR

Table 3.6 Tools Required

Description	Qty
Spanner 13mm	1
Support trestle	1
Thread-locking adhesive - low strength	



**Personal Injury Hazard.** The CCTS mass without medical equipment loaded is 200kg. Use suitable numbers of people to manoeuvre the unit during maintenance.



**Equipment Damage Risk.** Medical equipment and support brackets can become damaged during maintenance. To prevent damage, remove equipment.

#### 3.2.3.1 Removal

- Disconnect unit from mains supply.
- If installed, remove all medical equipment.
- If fitted, remove support tray as described in [para 3.2.8](#).
- Loosen thumb wheels and rotate IV drip pole to the side of unit. Alternatively IV drip pole and IV pole brackets can be removed as described in [para 3.2.6](#).
- With suitable assistance, lay CCTS on its front to gain access to castors. Rest top rail on a suitable support trestle.
- Remove 4off M8x20 bolts complete with M8 washers that fasten castor to base frame ([Fig 3.5](#)).
- Withdraw castor from base frame ([Fig 3.5](#)).

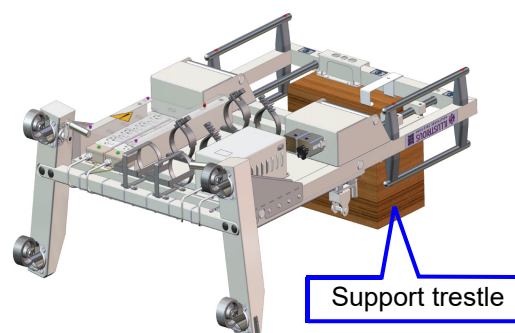

Fig 3.4 Lay Unit on its Front

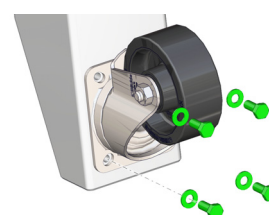

Fig 3.5 Remove/Fit Front Castor

#### 3.2.3.2 Fitting

- Apply thread-locking adhesive to 4off M8x20 bolts.
- Attach castor to base frame using 4off M8x20 bolts complete with M8 washers, and tighten ([Fig 3.5](#)).
- With suitable assistance, upright the unit.
- Check for correct operation.

## 3.2.4 REAR CASTOR & BRAKE ASSEMBLY

Table 3.7 Tools Required

Description	Qty
Spanner 13mm	1
Hex drive key 5mm	1
Hammer	1
Copper drift	1
Support trestle	1
Thread-locking adhesive - low strength	



**Personal Injury Hazard.** The CCTS mass without medical equipment loaded is 200kg. Use suitable numbers of people to manoeuvre the unit during maintenance.



**Equipment Damage Risk.** Medical equipment and support brackets can become damaged during maintenance. To prevent damage, remove equipment.



Note:

This procedure covers replacement of the brake assembly should it be required.

### 3.2.4.1 Removal

- Disconnect from mains supply, if installed, remove all medical equipment.
- If fitted, remove the support tray as described in [para 3.2.8](#).
- Loosen thumb wheels and rotate IV drip pole to the side of the unit. Alternatively IV drip pole and IV pole brackets can be removed as described in [para 3.2.6](#).
- With suitable assistance, lay CCTS on its front to gain access to the castors. Rest top rail on a suitable support trestle.
- Prise out 4 off M6 screw caps from brake lever screws and retain.
- Remove 4 off M6x12 screws that fasten brake lever to base frame (move brake lever as required for access to screws), slide brake lever out of frame ([Fig 3.7](#)).



Note:

It may necessary to use a hammer and drift ([Fig 3.8](#)), to aid removal of the brake lever.

- Remove 4 off M8x20 bolts complete with washers that fasten castor to base frame ([Fig 3.8](#)).
- Withdraw castor from base frame.

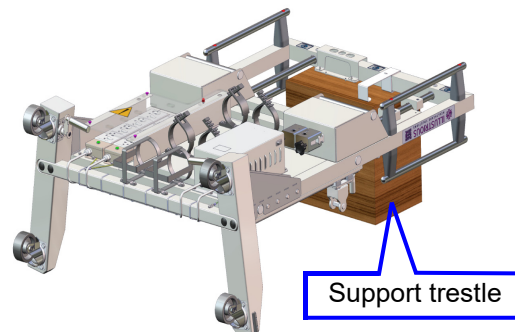

Fig 3.6 Lay Unit on its Front

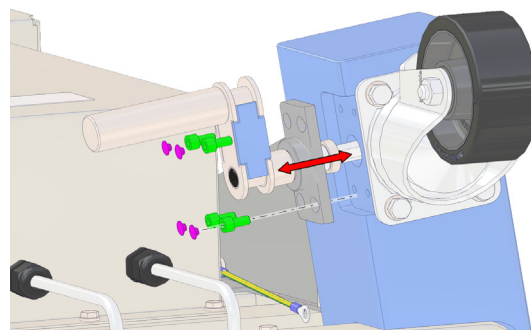
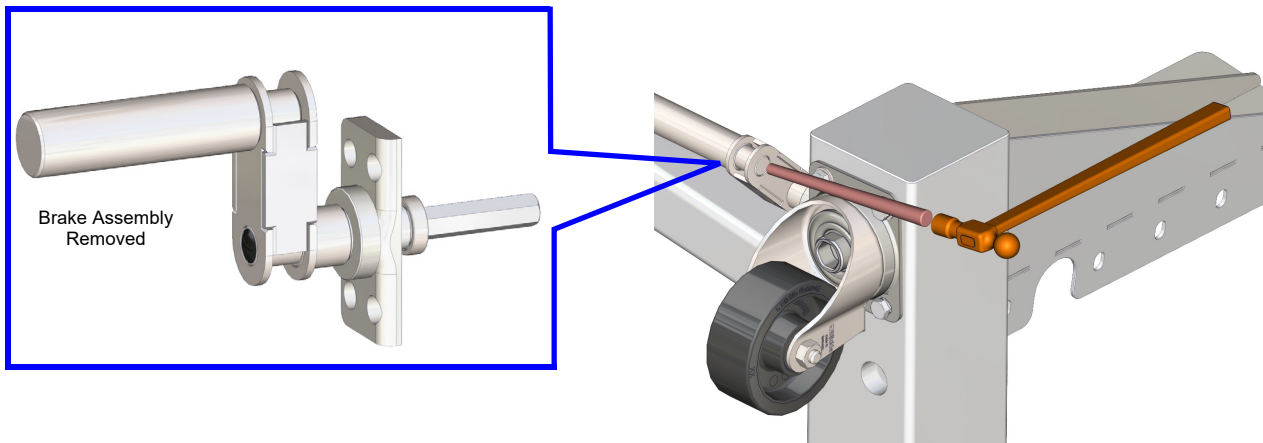

Fig 3.7 Remove/Fit Brake Lever



*Fig 3.8 Remove Brake Lever Assembly*

### 3.2.4.2 Fitting



**Note:**

With the brake assembly lever in disengaged position, make sure the top/bottom faces are parallel to the top/bottom faces of the angled leg (coloured blue in Fig 3.7) and the radius edge is aligned with the radius on the lower face (Fig 3.9 arrowed).

- Insert castor into base frame with arrow on top of boss facing forwards (Fig 3.10).
- Apply thread-locking adhesive to 4off M8x20 bolts and 4off M6x12 screws.

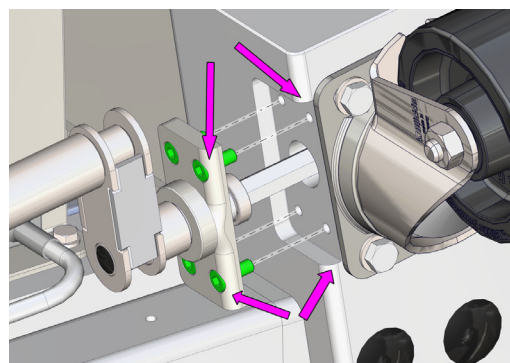

*Fig 3.9 Brake Assembly Alignment*

- Fit castor using 4off M8x20 bolts complete with washers, tighten (Fig 3.8).
- Orientate brake assembly in disengaged position and radii aligned (see note above).
- Align brake assembly with hole in base frame, insert brake operating bar through hole in side of base frame (Fig 3.8).
- Insert 4off M6x12 screws and tighten.
- Insert 4off M6 screw caps.
- With suitable assistance, upright the unit.
- Check for correct operation of brakes and castor.

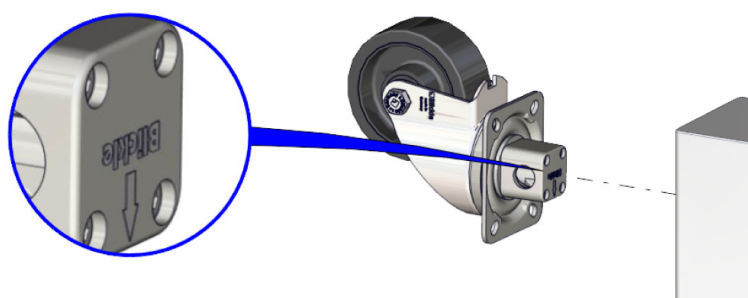

*Fig 3.10 Fitting of Rear Braked Castors*



### 3.2.5 SLIDE MECHANISM BEARING BLOCKS

Table 3.8 Tools Required

Description	Qty
Spanner 10mm	1
Spanner 28mm	2
Hex drive key 4mm	1

#### 3.2.5.1 Removal

- Make sure left hand mechanism lock levers are set to unlocked position (up).
- Remove fixing boss on top and bottom slide rails (1). A second spanner may be required to hold fixing boss at other end.
- Support slide mechanisms (3 and 4) while pulling top and bottom guide rails (2) out of frame.
- Move the slide mechanism away.

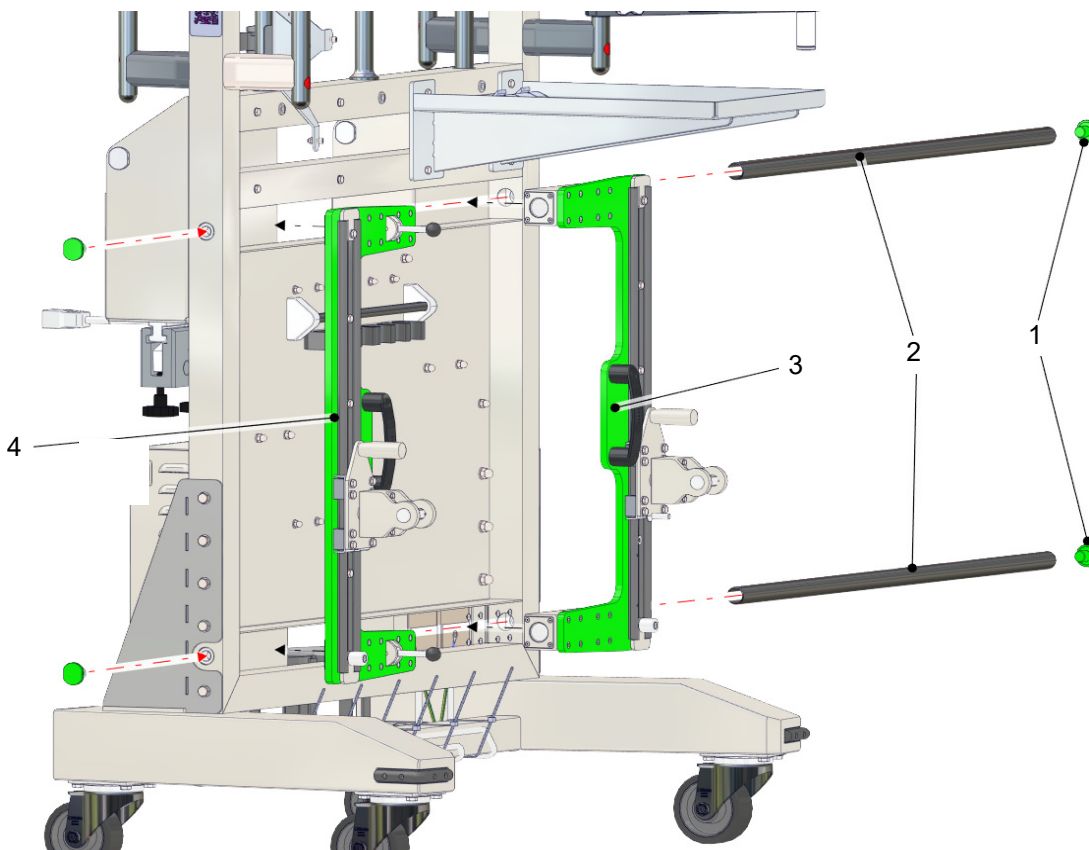
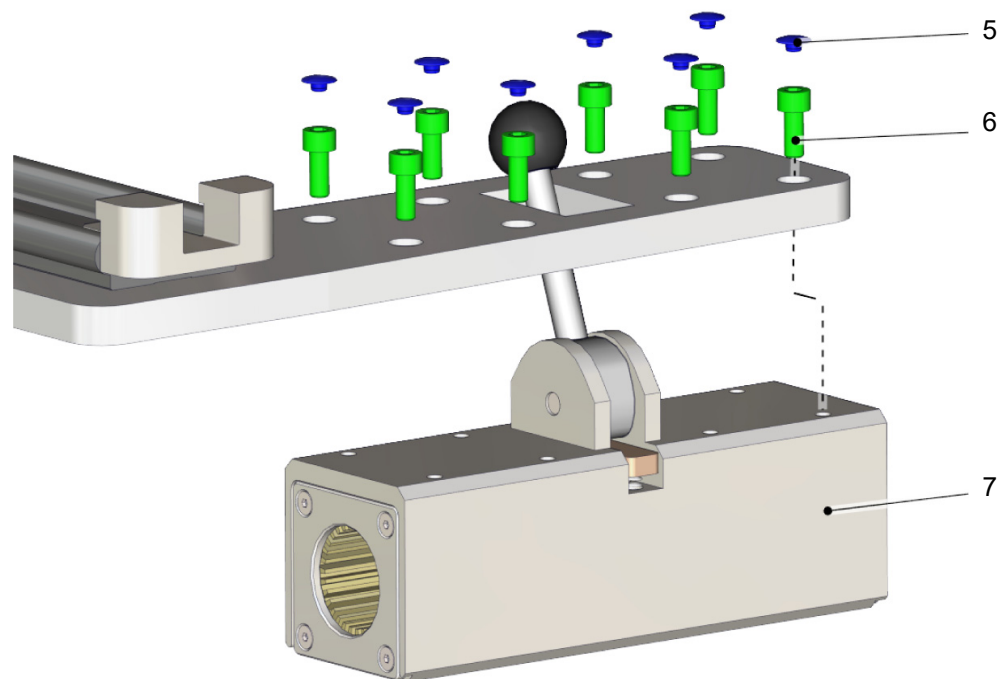

Fig 3.11 Remove/Fit Slide Mechanism Bearing Block

- Prise out 8off M5 screw caps (5) and retain.
- Remove 8off M5x12 screws (6) holding bearing block to slide mechanism base plate.
- Withdraw bearing block (7).



*Fig 3.12 Remove/Fit Bearing Block Assembly*



Note:

Image in [Fig 3.12](#), shows left hand locking bearing block. Right hand bearing block is same principle.

### 3.2.5.2 Fitting

- With reference to [Fig 3.12](#) locate new bearing block (7) on base plate (passing lever handle through aperture on left hand unit).
- Attach using 8off M5x12 screws (6) and tighten.
- Cover screw heads with 8off M5 screw caps (5).
- Make sure lock lever is set to unlocked position (up), left hand only.
- With reference to [Fig 3.11](#) hold slide mechanisms (3 and 4) on CCTS frame with bearing blocks in their respective gaps in frame.
- Slide guide rails (2) through each bearing block until they protrude and push them through holes in frame upright.
- Insert fixing boss (1) into each guide rail and tighten.
- Test operation.



## 3.2.6 IV DRIP POLE

### 3.2.6.1 Removal

- Remove any equipment mounted on IV drip pole (3). Turn 2 off outer thumb wheels (4) counter-clockwise to loosen.
- Lift IV drip pole (3) up and through IV pole brackets (2).

### 3.2.6.2 Fitting

- Loosen 2 off outer thumb wheels (4) counter-clockwise.
- Lower IV drip pole (3) through both IV pole brackets (2) to desired height.
- Tighten 2 off outer thumb wheels (4) to tighten clamp.
- Make sure IV drip pole (3) is secure.

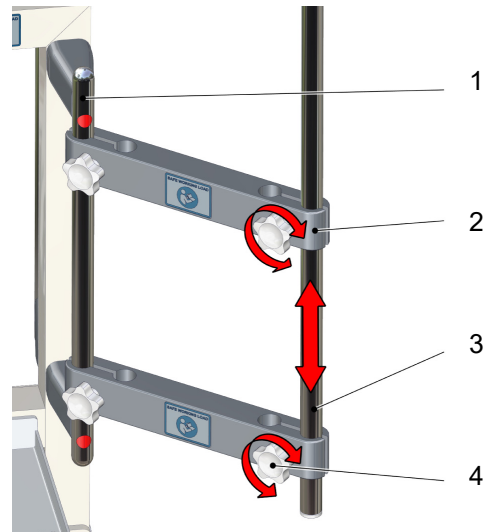

Fig 3.13 Remove/Fit IV Drip Pole

## 3.2.7 IV DRIP POLE COMPLETE WITH BRACKETS

The IV drip pole can be mounted on either left or right hand side of unit.

Table 3.9 Tools Required

Description	Qty
Hex drive key 8mm	1

### 3.2.7.1 Removal

- Remove any equipment mounted on IV drip pole assembly. Prise out 2 off screw caps (3) and retain.
- Remove 2 off M10x40 screws.
- Lift handle (1) off unit, complete with IV drip pole assembly.
- Turn 2 off inner thumb wheels (5) counter-clockwise to loosen.
- Lift handle (1) up and through IV pole brackets (4).

### 3.2.7.2 Fitting

- Loosen 2 off inner thumb wheels (5) counter-clockwise.
- Lower handle (1) through both IV pole brackets (4).
- Tighten 2 off inner thumb wheels (5) to tighten clamp.
- Mount handle, complete with IV drip pole assembly, using 2 off M10x40 screws.
- Make sure handle (1) and IV drip pole assembly are secure.
- Insert 2 off screw caps (3).

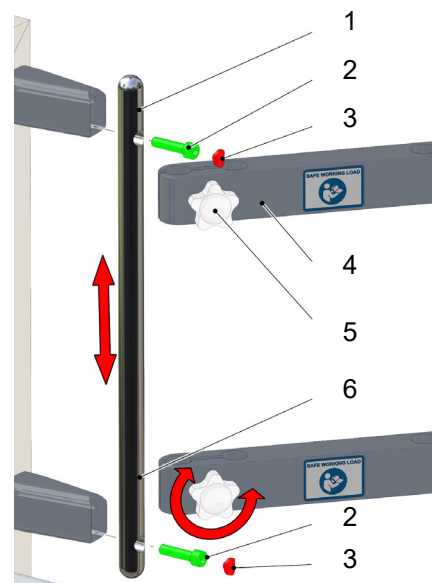

Fig 3.14 Remove/Fit IV Drip Pole Brackets



### 3.2.8 SUPPORT TRAY

*Table 3.10 Tools Required*

Description	Qty
Spanner/socket 10mm	1

The support tray can be removed for repair/replacement or if not needed. It can be fitted at 3 positions (left, right & centre) along cross beam of frame.

#### 3.2.8.1 Removal

- Remove 4off M6x30 bolts complete with washers, holding tray bracket to CCTS frame.
- Remove tray.

#### 3.2.8.2 Fitting



Note:

If changing position of the tray it will be necessary to reinstall M6x16 bolts in unused holes to eliminate dirt traps.

- If necessary remove and relocate M6x16 bolts.
- Locate tray in desired position on cross beam of frame.
- Fix in position with 4off M6x30 bolts complete with washers, and tighten.

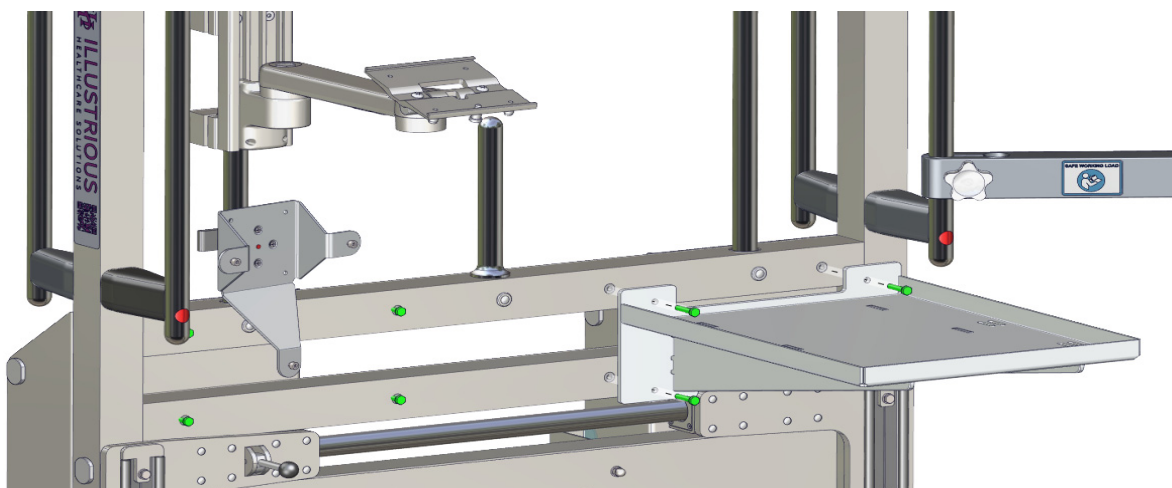

*Fig 3.15 Remove/Fit Support Tray (Three optional positions)*



# PART 4 TROUBLESHOOTING

## 4.1 TROUBLESHOOTING

Most problems can be corrected by the user, however, others will require the assistance of a suitably qualified person.

In the event that the suitably qualified person is unable to correct the problem, contact the manufacturer for further information or to arrange repair / order spares, see rear cover for contact details.



**Personal Injury Hazard.** If there is any suspicion that the CCTS is not fit for purpose, do not use it. Seek advice from your supervisor.



**Personal Injury Hazard.** Do not undertake any maintenance on this product unless you are suitably qualified and experienced. Any attempt to maintain or repair the unit when not competent may lead to injury of personnel.



**Personal Injury Hazard.** Continued use of CCTS with broken components may cause a danger to personnel or further damage to the unit. Remove the CCTS from use until the component is replaced.



**Personal Injury Hazard.** Switch off and disconnect mains power prior to undertaking maintenance on the unit.



*Table 4.1 Troubleshooting Guide*

No.	Problem	Cause	Solution
1	No power to unit/power distribution units green light not illuminated.	Mains power cable not plugged in.	Plug in mains power cable.
		Mains power not switched on.	Switch on mains power at socket on wall.
		Cable connector not fully mated at transformer.	Fully mate connector.
		Isolation transformer thermal circuit breaker has tripped.	Reset thermal circuit breaker.
		Main power cable fuse blown.	Check fuse in main power cable.
2	Thermal circuit breaker keeps tripping after reset.	Electrical problem.	Investigate & repair.  Check problem not isolated to station in use by trying an alternative wall socket. If trying another socket does not resolve, remove CCTS from use and contact a suitably qualified maintenance engineer.
		Electrical load greater than 5A.	Reduce demand.
3	Medical equipment not working.	No power to CCTS.	Connect and switch on mains power at socket on wall.
		PDU not switched on.	Switch PDU on.
		Medical equipment not switched on/plugged in.	Switch on/plug in medical equipment.
		Medical equipment plug fuse blown.	Check fuse in plug.
		Isolation transformer thermal circuit breaker has tripped.	Reset circuit breaker.

Continued



*Table 4.1 Troubleshooting Guide (continued)*

No.	Problem	Cause	Solution
4	Slide mechanisms move while CCTS in transit.	Slide mechanism locking levers not in locked position.	Move locking levers to locked position (fully down).
		Left hand locking bearing block defective.	Replace.
5	CCTS slide mechanism won't move.	Slide mechanism locked.	Check both top and bottom lock levers fully disengaged (fully up).
		Foreign objects in mechanism.	Check/clean mechanism.
		Bearing block defective.	Replace ( <a href="#">para 3.2.5</a> ).
6	CCTS slide mechanism won't lock.	Locking levers not engaged.	Check locking levers fully down.
		Slide mechanism bearing block faulty.	Replace ( <a href="#">para 3.2.5</a> ).
7	Medical equipment moving in transit.	Fixings/fittings loose.	Tighten.
8	CCTS won't move.	Brakes on CCTS and/or bed engaged.	Disengage brakes.
		Foreign objects in castors.	Check/clean castors.
		Castor damaged.	Replace ( <a href="#">para 3.2.3/para 3.2.4</a> ).
		Castor brake mechanism faulty.	Replace ( <a href="#">para 3.2.4</a> ).
9	CCTS brakes will not engage.	Castor faulty.	Replace castor ( <a href="#">para 3.2.4</a> ).
		Castor brake mechanism faulty.	Replace castor brake mechanism ( <a href="#">para 3.2.4</a> ).

Continued



*Table 4.1 Troubleshooting Guide (continued)*

No.	Problem	Cause	Solution
10	CCTS brakes will not disengage.	Castor faulty. Castor brake mechanism faulty.	Replace castor ( <a href="#">para 3.2.4</a> ). Replace castor brake mechanism. ( <a href="#">para 3.2.4</a> ).
11	Castor won't swivel.	Castor faulty.	Replace castor ( <a href="#">para 3.2.3/para 3.2.4</a> ).
12	Gas cylinder strap will not fasten.	Strap faulty.	Replace strap ( <a href="#">para 3.2.2</a> ).



### 5.1 MANUFACTURER'S ADDITIONAL INFORMATION

#### 5.1.1 ACRONYMS

Table 5.1 Acronyms

Acronym	Full Meaning	Acronym	Full Meaning
A	Ampere/Amps	mm	Millimetre
CCTS	Critical Care Transfer Stack	MRI	Magnetic Resonance Imaging
Hz	Hertz	PDU	Power Distribution Unit
hPa	Hectopascal	QR	Quick Reference
IHS	Illustrious Healthcare Solutions	SWL	Safe Working Load
IV	Intravenous	UKCA	United Kingdom Conformity Assessed
kg	Kilogram	V	Volts
m	Metre	WEEE	Waste Electrical and Electronic Equipment

#### 5.1.2 LIFE DATA

CCTS operational life is 10 years from first use provided the mid-life components detailed in [Table 3.1/](#)[Table 3.2](#) are replaced at the 5 year point.

#### 5.1.3 TECHNICAL DATA

Table 5.2 Dimensions & Mass

Dimension	Measurement
Height	1,625mm (excluding adjustable components) 1,855mm including IV pole
Width	1,172mm (excluding adjustable components) 1,286mm including IV pole
Depth	608mm
Equipment	Weight
CCTS (unladen)	200kg
CCTS (with full suite of typical medical equipment fitted)	245kg

*Table 5.3 Specifications*

Field	Detail
Registered trade name	Electromechanical Device / System Transport Trolley
Model reference number	PA1478-2003
Global medical device nomenclature	Number 40596
Registration business name	Illustrious Healthcare Solutions
Medical equipment class	Class I under 93/42/EEC medical device directive
Intended purpose	Mobile transfer device that accommodates a variety of medical equipment essential to support the intra-hospital transport of patients whilst attached to a critical care bed
Contraindications	CCTS does not have any contraindications
Electric supply	230V, 50Hz standard domestic power supply
Electrical load	Not to exceed 4A
Thermal circuit breaker trip	>5A
Applied parts	Nil parts that come into physical contact with the patient in CCTS
Programmable electrical medical systems	No programmable electronic medical systems fitted to CCTS

*Table 5.4 Environmental Condition Limits*

In Service	Min	Max
Temperature	+5°C	+40°C
Atmospheric pressure	500hPa	1,100hPa
Altitude above sea level		4,000m
Relative humidity	5%	95%
Storage and Transport	Min	Max
Temperature	-30°C	+80°C
Atmospheric pressure	500hPa	1,100hPa
Altitude above sea level		4,000m
Relative humidity	5%	95%



---

#### 5.1.4 PROTECTIVE FINISH

The unit is protected with a powder coating paint finish that incorporates antimicrobial properties. This type of finish aids cleaning and hygiene.

#### 5.1.5 ELECTROMAGNETIC INTERFERENCE

As an electro-medical device, this CCTS is subject to special safety measures with respect to electromagnetic compatibility.

Portable and mobile high-frequency communication devices (e.g. cordless telephones, mobile telephones, wireless equipment etc.) can influence the operation of electro-medical equipment. These influences have been minimised by means of the robust, interference-resistant design of the electrical features of the CCTS.

As with every electrical device, even if all the specified electromagnetic compatibility limits are adhered to during operation, interference from other nearby high-frequency communication devices and vice versa cannot be eliminated completely (e.g. “crackling” in a radio). In such rare cases, increase the distance between the devices or align them differently, and make sure that they do not use the same electrical outlet, or switch the disruptive/disrupted device off temporarily.

#### 5.1.6 DISPOSAL



In accordance with 2012/19/EU WEEE Directive Compliance, the CCTS unit is classified as electrical and electronic equipment and should be disposed of separately, not as unsorted municipal waste. The crossed-bin symbol located on the device invites you to use the appropriate collection, reuse and recycling systems available in your region. The design of these collections will help minimise the unit's environmental footprint, reduce pressure on natural resources, and prevent the risk of hazardous substances from causing environmental damage. If you need information on these disposal systems, contact your local council, regulatory agency, or an appropriate waste disposal company.





---

### 5.1.7 DOCUMENT CONTENT

Queries concerning the content of this document, or proposals for change, are to be sent to the address below or by scanning the quick response (QR) code on the rear cover and following the link to the customer feedback form (see [para 5.2](#)):

Illustrious Healthcare Solutions  
Airport Service Road  
Portsmouth, Hampshire  
United Kingdom  
PO3 5PF

Email: [info@ihealths.co.uk](mailto:info@ihealths.co.uk)  
Telephone: +44 (023) 9266 2251

### 5.1.8 PROPRIETARY INFORMATION

This document may contain information or technical data (technology) that is proprietary to Illustrious Healthcare Solutions Limited and may be subject to the UK Export Control Act 2002 and the associated Export Control Order 2008 (as amended). Such information and technical data (technology) is meant only for the specified recipient and transfer to a third party is strictly forbidden without the written approval of Illustrious Healthcare Solutions Limited.

When authorised to do so, recipients are to destroy this document by methods that will prevent any further disclosure or reconstruction of its content.

Any breach or infringement of the export laws within the act is illegal and subject to severe penalties upon conviction. Unauthorised disclosure of this information or data (technology), secured under a duly signed confidentiality agreement, memorandum of understanding, technical assistance agreement or other such document is prohibited.



# ANNEX B

## USER FEEDBACK FORM

### 5.2 FEEDBACK FORM

Should you have any comments directly attributable to, or associated with, CCTS, complete the feedback form below and send to either:

- info@ihealths.co.uk or
- Illustrious Healthcare Solutions, Airport Service Road, Portsmouth, Hampshire, PO3 5PF, United Kingdom.

#### 5.2.1 TYPES OF FEEDBACK

- Death or serious deterioration in health of the patient/client, user or any other person:
  - Occurred.
  - Might have occurred.
- Positive feedback (may include suggested improvements, positive experiences, etc).

#### 5.2.2 FEEDBACK CONSIDERATIONS

- Activation, positioning or separation.
- Adverse event.
- Calibration.
- Compatibility.
- Connections/interfaces.
- Contamination/decontamination.
- Electrical/electronic property.
- Environmental compatibility.
- Fitting-related.
- Human-device interface.
- Label, instructions for use or training.
- Manufacturing, packaging or shipping.
- Material integrity.
- Mechanical.
- Optical.
- Patient-device incompatibility.
- Protective measures.
- Temperature.
- Use of device.



Note:

This is not an exhaustive list of potential user feedback.



### Contact details of the reporting user (organisation/person)

Name of organisation:	
Organisation address:	
Organisation postcode:	
Country:	
Point of contact name:	
Point of contact phone number:	
Point of contact position:	
Point of contact e-mail:	
Report date:	
Reporter's report identifier:	

### Product details

Product name:	Critical Care Transfer Stack
Product code/catalogue number(s):	PA1478-2003
Serial number(s):	__ / PAM / ____ (See identity plate)
Instructions for use version number:	Rev _ (See footer of this document)
UDI-DI:	(01)5056549700340
UDI-PI:	(11)____ (21) __ PAM ____ (See identity plate)
Manufacturer name:	Illustrious Healthcare Solutions
Manufacturer contact details (e-mail):	info@ihealths.co.uk

### Event details

Describe the clinical/analytical procedure during which the observation was made:



## Event details

Event description (e.g. in the event of negative feedback, explain what went wrong with the medical device, and what was the health impact [death, life-threatening, indirect harm such as misdiagnosis or delayed diagnosis/treatment], and in the event of positive feedback, explain suggestions for improvement or positive experiences):

Date of observation/event:

% of devices involved:

Number of devices involved:

Number of patients involved:

Operator/user at the time of the observation/event (please choose):

Healthcare professional

Patient/lay user

Other (specify)

Has more than one user had the observation with the product? (please choose):

Yes

No

Comments:

Date of report:

.....

Signature:

.....

Disclaimer: The act of reporting an observation is not an admission of manufacturer, user or patient liability for the event or its consequences.

Intentionally Blank



Scan me for online information and  
electronic Instructions for Use

**CONTACT:**

Illustrious Healthcare Solutions Ltd  
Airport Service Road  
Portsmouth  
PO3 5PF



+44 (0) 23 9262 662251



[www.ihealths.co.uk](http://www.ihealths.co.uk)



[info@ihealths.co.uk](mailto:info@ihealths.co.uk)